

Attachment A1

**Planning Proposal Justification Report
757-763 George Street, Haymarket**



757-763 George Street, Haymarket

Planning Proposal

On behalf of
Samprian Pty Ltd
October 2020



Project Director

Ben Hendriks – Managing Director

Revision	Revision Date	Status	Authorised	
			Name	Signature
REV 01	1 August 2020	Draft	AD/CM	-
REV 02	15 October	Final Draft	AD	BH
REV 03	30 October	Final	AD	-

* This document is for discussion purposes only unless signed and dated by the persons identified. This document has been reviewed by the Project Director.

Contact

Mecone

Level 12, 179 Elizabeth Street
Sydney, New South Wales 2000

info@mecone.com.au
mecone.com.au

© Mecone

All Rights Reserved. No part of this document may be reproduced, transmitted, stored in a retrieval system, or translated into any language in any form by any means without the written permission of Mecone.

All Rights Reserved. All methods, processes, commercial proposals and other contents described in this document are the confidential intellectual property of Mecone and may not be used or disclosed to any party without the written permission of Mecone.

Table of Contents

Executive Summary	1
1 Introduction.....	5
1.1 Proponent and Project Team.....	6
1.2 Relevant Development Applications.....	7
2 Site Context and Description.....	9
2.1 Site Analysis	9
2.2 Legal Description and Ownership	10
2.3 Site Description.....	11
2.3.1 Heritage	13
2.4 Surrounding Development	14
2.5 Future Development Context	17
2.5.1 Haymarket/Ultimo Tower Cluster Area.....	17
2.5.2 187 Thomas Street Planning Proposal.....	17
2.5.3 Central State Significant Precinct.....	19
2.6 Planning Context	20
2.6.1 Regional Planning Context.....	21
2.6.2 Local Planning Context.....	23
3 Key Current Planning Controls	24
3.1 Sydney Local Environmental Plan 2012	24
3.1.1 Zoning.....	24
3.1.2 Building Height	24
3.1.3 Floor Space Ratio.....	25
3.2 Sydney Development Control Plan 2012.....	26
4 Indicative Development Context	28
4.1 Overview of Preferred Scheme.....	28
4.1.1 Urban Design	30
4.1.2 Tower Envelope and Massing	30
4.1.3 Podium and Street Frontage Height	31
4.1.4 Tower Setbacks	32
4.1.4.1 Street Setbacks	32
4.1.4.2 Side and Rear Setbacks	33
4.1.5 Public Domain and Landscaping.....	34

4.1.6	Uses and Gross Floor Area	34
4.1.6.1	Vehicular Access	35
4.1.6.2	Pedestrian Access	36
4.1.7	Public Domain Upgrades	36
4.2	Proposed DCP Envelope.....	36
4.3	Design Excellence and Development Options	38
5	Planning Proposal Overview.....	39
6	Part 1 - Objectives and Intended Outcomes of the Planning Proposal.....	40
7	Part 2 - Explanation of Amending the LEP Provisions	42
7.1.1	Amendments to Sydney Local Environmental Plan 2012	42
7.1.2	Proposed Site Specific Provision.....	42
7.1.3	Distribution of Floor Space Ratio	43
7.2	Amendments to the SDCP 2012.....	44
8	Justification.....	45
8.1	Section A - Need for the Planning Proposal.....	45
8.2	Section B - Relationship to Strategic Planning Framework.....	46
8.2.1	A Metropolis of Three Cities – The Greater Sydney Region Plan.....	47
8.2.2	Eastern City District Plan.....	48
8.2.3	Camperdown-Ultimo Place Strategy	51
8.2.4	The Central to Eveleigh Urban Transformation Strategy	52
8.2.5	NSW State Infrastructure Strategy 2018 – 2036	53
8.2.6	Future Transport Strategy 2056	53
8.2.7	Central Sydney Planning Strategy	56
8.2.8	Sustainable Sydney 2030.....	59
8.2.9	City Plan 2035 – Local Strategic Planning Statement	60
8.2.10	Visitor Accommodation Action Plan.....	67
8.2.11	Retail Action Plan.....	68
8.2.12	Tourism Action Plan.....	68
8.2.13	A Change in Context and Circumstances.....	69
8.2.14	Economic Justification and Prevailing Market Conditions	70
8.3	Section C - Environmental, Social and Economic Impact.....	77
8.4	Section D - State and Commonwealth Interests	78

9	Environmental Assessment	79
9.1	Built form and Urban Design	79
9.1.1	Podium	79
9.1.2	Tower Element	80
9.1.3	Tower Separation and Setbacks	82
9.1.3.1	Northern Setback	83
9.1.3.2	Southern Setback	85
9.1.3.3	Eastern Setback	86
9.1.3.4	Cantilevering Element	86
9.2	Overshadowing	87
9.3	Visual Impact	88
9.4	Equivalence Testing	92
9.4.1	Daylight Analysis	93
9.4.2	Pedestrian Wind Comfort and Safety	93
9.5	Design Excellence	94
9.6	Solar Access	94
9.7	Noise Impacts	95
9.8	Heritage	95
9.9	Transport, Traffic and Parking	97
9.9.1	Statutory Parking Assessment	97
9.9.2	Traffic Generation	98
9.9.3	Access Arrangements	98
9.10	Geotechnical	98
9.11	Contamination	98
9.12	Stormwater	99
9.13	Public Art	99
9.14	Sustainability	100
9.15	Voluntary Planning Agreement	101
9.16	Social and Economic Benefits	101
10	Mapping	102
11	Community Consultation	103
12	Indicative Project Timeline	104
13	Conclusion	105

Schedule of Figures

Figure 1 Approved Setbacks Above the Street Frontage (Levels 3 - 4)	7
Figure 2 Approved Setbacks Above the Street Frontage (Levels 8 – 13)	8
Figure 3 Context Map	9
Figure 4 Context Aerial Site Map	10
Figure 5 Site Aerial Map	11
Figure 6 Site Viewed Looking North West from George Street	12
Figure 7 Heritage Listed Building at 761 – 763 George Street Viewed Looking North..	12
Figure 8 Site and Surrounding Heritage Items	14
Figure 9 View of Christ Church St. Laurence Looking East Down Valentine Street	15
Figure 10 Fine-Grained Retail Uses Along George Street Looking North East	16
Figure 11 High Rise Developments Viewed From Valentine Street Looking West	16
Figure 12 Site's Location within the Haymarket / Ultimo Tower Cluster Area.....	17
Figure 13 DCP Envelope for 187 Thomas Street Viewed Looking South West.....	18
Figure 14 Base Case Envelope for 187 Thomas Street Viewed Looking North East.....	18
Figure 15 Indicative Location of Future Towers.....	20
Figure 16 The Site's Strategic Context	21
Figure 17 Land Zoning Map	24
Figure 18 Existing Height of Buildings Map	25
Figure 19 Existing Floor Space Ratio Map	26
Figure 20 Preferred Scheme Viewed South (Above) and West (Below)	29
Figure 21 Preferred Scheme Envelope Configuration Viewed Looking North West ...	31
Figure 22 Preferred Scheme's Street Wall Height Viewed from George Street	32
Figure 23 Preferred Scheme's Proposed Eastern Side Setbacks.....	33
Figure 24 Preferred Scheme's Proposed Northern Setback.....	33
Figure 25 Landscaping Within External Terrace Area (Level 3).....	34
Figure 26 Vehicular Entrance off Valentine Street and Continuous Active Frontage	35
Figure 27 Proposed DCP Envelope.....	37
Figure 28 Site's Location within the Haymarket / Ultimo Tower Cluster Area.....	56
Figure 29 Compliant Eastern Setback and Street Wall of 20m	79
Figure 30 Proposed Setback and Street Wall Height	80
Figure 31 Proposal and Existing and Planning Towers Viewed Looking North	81
Figure 32 Proposal and Surrounding Further Developments Viewed Looking West	82

Figure 33 Proposed Massing and Tower Setbacks	83
Figure 34 Typical Floor Plan of the 'Capitol Terrace' and Location of Windows	84
Figure 35 Location of Northern Building's Southern Facing Windows	84
Figure 36 Railway Square Solar Access Plan in Relation to the Site	88
Figure 37 View Down Valentine Street Towards Christ Church St Laurence	90
Figure 38 View from Thomas and Quay Streets Looking East	90
Figure 39 View from the George Street Frontage Looking South West	91
Figure 40 Public Views Protection Map / Central Station Clock Tower View Corridor	91
Figure 41 View of Preferred Envelope from Railway Square Looking West.....	92
Figure 42 Potential Locations for Public Art Within Site	100

Schedule of Tables

Table 1 – Project Team.....	6
Table 2 – Property Description(s)	10
Table 3 – Site Description.....	13
Table 4 – Proposed Uses and Gross Floor Area (Above Ground).....	35
Table 5 – Intended Built Form Outcomes	41
Table 6 – Application of the Various Floor Space Provisions Under the SLEP 2012...	44
Table 7 – Consistency with the Planning Priorities of the Eastern City District Plan ..	49
Table 8 – Consistency with Camperdown-Ultimo Place Strategy.....	51
Table 9 – Consistency with the Key Moves of the CSPA	57
Table 10 – Consistency with the Relevant LSPS Priorities.....	62
Table 11 – LSPS's Strategic and Site Specific Principles for Growth.....	64
Table 12 – Consistency with State Environmental Planning Policies	71
Table 13 – Section 9.1 Ministerial Directions	73
Table 14 – Project Timeline	104

Appendices

- **Appendix 1.** Survey
- **Appendix 2.** Architectural Design Report
- **Appendix 3.** Landscape Concept Plans
- **Appendix 4.** Site Specific DCP
- **Appendix 5.** Economic Impact Assessment
- **Appendix 6.** ESD Report
- **Appendix 7.** Supply and Demand Analysis
- **Appendix 8.** Remediation Action Plan
- **Appendix 9.** Flood Certification Statement
- **Appendix 10.** Pedestrian Wind Environment Study
- **Appendix 11.** Design Excellence Strategy
- **Appendix 12.** Daylight Analysis
- **Appendix 13.** Noise Impact Assessment
- **Appendix 14.** Heritage Impact Assessment
- **Appendix 15.** Historical Archaeological Assessment
- **Appendix 16.** Traffic Impact Statement
- **Appendix 17.** Preliminary Geotechnical Report
- **Appendix 18.** Stormwater Concept Plans
- **Appendix 19.** Preliminary Public Art Plan
- **Appendix 20.** Services Design Brief

Under Separate Cover

Proposed Public Benefit Offer

Executive Summary

This Planning Proposal has been prepared by *Mecone NSW Pty Ltd* (Mecone) on behalf of *Samprian Pty Ltd* (Samprian) in relation to the land located at 757 – 759 and 761- 763 George Street, Haymarket (the site). The Planning Proposal satisfies the requirements of Section 3.33 of the *Environmental Planning and Assessment Act 1979* (EP&A Act) and has been prepared in accordance with the NSW Department of Planning, Industry and Environment's (DPIE's) *A Guide to Preparing Planning Proposals* (2018).

Subject Site

The site is located on the south western fringe of Central Sydney and has an area of 1,030m². The site located at 757 – 759 is occupied by a four (4) storey mixed use building whilst the site located at 761 – 763 George Street contains a two storey heritage listed building identified as the Sutton Forest Meat Building (1843) under the *Sydney Local Environmental Plan 2012* (SLEP 2012). The building's heritage significant fabric is limited to its façades that front Valentine Street and George Street.

Overview of the Proposal

The Planning Proposal has been prepared under the guise of the Draft Central Sydney Planning Strategy (Draft CSPPS) which proposes a suite of amendments to the SLEP 2012. This Planning Proposal therefore needs to be interpreted within the context of the future controls associated with the Draft CSPPS.

The Planning Proposal seeks consent to introduce a site specific clause to Division 5 of the SLEP 2012 principally to permit a maximum:

- Building height of RL 117.87 (105.87m from ground level);
- Floor Space Ratio (FSR) of 12:1 above ground; and
- FSR of 2:0 below ground for specific ancillary uses.

A draft Site Specific Development Control Plan (DCP) also accompanies the Planning Proposal to provide certainty that a suitable development outcome is achievable at the detailed Development Application phase.

Project Vision

The Planning Proposal is accompanied by an indicative Preferred Scheme which reflects the Proponent's vision for the site as facilitated by the LEP amendments. It demonstrates that the Planning Proposal is capable of delivering a slender tower containing mid-range 3.5-star hotel accommodation and retail uses. The development facilitated by the proposal will provide complementary uses to cater to the growing tech industry as southern Central Sydney experiences a shift to higher-order employment uses.

The tower envisaged by this Planning Proposal will be integrated with the existing heritage building contained within the site. In light of this, the proposal seeks to adaptively reuse the heritage item to facilitate its repurposing for a contemporary use in a manner that continues to reinforce the local character of the area.

Strategic Merit

The appropriateness of the Planning Proposal needs to be understood in the context of the strategic planning framework and the future surrounding development that will emerge in response to this framework.

The site is located on the south western edge of the Harbour CBD which is designated by the *Greater Sydney Region Plan – A Metropolis of Three Cities* (the Greater Sydney Plan) as Australia's global gateway and financial capital. A key objective of the Greater Sydney Region Plan is to make the Harbour CBD stronger and more competitive. The diversification of the Harbour CBD's assets and uses is noted as being integral to promoting its economic strength and competitiveness. The proposal aligns with the objective in that it will assist in increasing the variety of uses in the Harbour CBD by providing high quality visitor accommodation and retail floor space.

Within the Harbour CBD, the site forms part of the emerging Innovation Corridor. The Innovation Corridor is earmarked to accommodate international innovation companies, universities and start-ups as well as complementary uses that together will provide the opportunity for agglomeration benefits. The Greater Sydney Plan notes that to support the emergence of the Innovation Corridor, a flexible approach to the application of the planning controls is required. This is particularly important in the context of a forecast shortfall of office floor space in the mid to long term. To address this shortfall, the Greater Sydney Region Plan notes there is a need to maximise vertical development opportunities, particularly within southern Central Sydney and along the Innovation Corridor. In light of this, the Planning Proposal optimises the opportunity to increase the site's capacity to support employment generating floor space and complementary retail and accommodation uses that will contribute to the growth of the Innovation Corridor.

The Draft CSPA locates the site within the Haymarket / Ultimo Tower Cluster Area which is earmarked for densification. The site is also located to the direct west of Central State Significant Precinct (SSP) (Central Precinct) which will support towers of unprecedented scales and will form the focal point of the emerging Sydney Innovation and Technology Precinct.

In this context, the Planning Proposal aligns with the strategic aspirations that apply to the locality in that it will contribute to the emergence of the Tower Cluster Area and will facilitate a suitably scaled tower that sits comfortably in the context of the future surrounding development.

In addition to being strategically positioned within a Tower Cluster Area, Council's Local Strategic Planning Statement, *The City Plan 2036 (LSPS)* situates the site within the Central Sydney South Precinct. This precinct is identified as a strategically important employment area designated to support the expansion of Sydney Central Business District's office market. The Planning Proposal aligns with the priorities for the precinct as it will increase the site's capacity to accommodate employment generating floor space.

The LSPS identifies that the demand for hotels in Central Sydney is anticipated to grow by 4.7% annually to 2020. In light of this, the Planning Proposal will address the

growing demand for hotel accommodation precipitated by the flux of corporate travelers associated with the growing office market in southern Central Sydney.

The Planning Proposal envisages mid-range hotel accommodation for the site. By providing mid-range hotel accommodation, the Planning Proposal will also address the growing demand identified by the LSPS for affordable mid-range hotel options in the context of there being an oversupply of high-end hotel accommodation concentrated in the Sydney CBD.

Site Specific Merit

The Preferred Scheme that accompanies the Planning Proposal is the outcome of iterative design testing and has been prepared to demonstrate the site specific merits of the Planning Proposal.

The Planning Proposal demonstrates site specific merit as it:

- Provides an improved amenity outcome for surrounding properties;
- Will deliver a contemporary built form sympathetic to the site's heritage fabric;
- Will capitalise on the site's excellent access to existing and planned transport infrastructure;
- Is capable of providing equivalent / improved pedestrian wind comfort and daylight access to the ground plane;
- Will protect and enhance the site's important heritage;
- Facilitates an envelope with capacity to support a tower at the Development Application stage that exhibits design excellence;
- Increases the site's capacity to accommodate employment generating floor space;
- Provides a bulk and scale commensurate with future surrounding developments;
- Will deliver a range of public and economic benefits, including:
 - A gross value added (GVA) contribution of \$10 million per year;
 - increased investment associated with hotel guests' expenditure in nearby food, retail and services amounting to approximately \$11.4 million per year;
 - 129 full-time operational jobs; and
- Will have acceptable environmental impacts as evidenced by supporting subconsultant reports.

In light of the above, the Planning Proposal will facilitate the achievement of a myriad of economic benefits. These benefits can be realised without giving rise to any adverse environmental social or economic impacts.

Conclusion

The proposal is consistent with the aims and objectives of the relevant strategic and statutory plans and policies. It is therefore considered that the proposal satisfies both the Strategic Merit Test and Site Specific Merit Test. It is therefore requested that Council forward this Planning Proposal to the Minister for Planning for Gateway Determination.



1 Introduction

This Planning Proposal has been prepared by *Mecone NSW Pty Ltd* (Mecone) on behalf of Samprian in relation to the site located at 757 - 759 and 761 - 763 George Street, Haymarket.

The Planning Proposal seeks to introduce a site specific clause to Division 5 of the SLEP 2012 to increase the site's permissible:

- Height from 50m to RL 117.87 (105.87m from ground level); and
- FSR from 7.5:1 to 12:1 above ground.

The Planning Proposal is accompanied by a Site Specific DCP which proposes amendments to the Sydney DCP 2012 (SDCP 2012) to facilitate the achievement of the desired built form at the detailed Development Application phase.

The Planning Proposal has been prepared in accordance with:

- Section 3.33 of the EP&A Act; and
- The DPIE's - *A Guide to Preparing Planning Proposals (2018)*.

Specifically, the Planning Proposal includes the following information:

- Part 1 – Objectives and intended outcomes
- Part 2 – Explanation of provisions
- Part 3 – Justification for the proposed LEP amendments, including:
 - Need for the Planning Proposal
 - Relation to strategic planning framework
 - Environmental, social and economic impacts
 - State and Commonwealth interests
- Part 4 – Mapping
- Part 5 – Community Consultation

This Planning Proposal has been prepared with regard to the City of Sydney *Draft Central Sydney Planning Strategy* (Draft CSPS) and the associated LEP amendments as exhibited by Council from 1 May to 10 July 2020.

1.1 Proponent and Project Team

The Planning Proposal has been prepared on behalf of the Proponent, Samprian. The details of the project team are included in the table below.

Table 1 – Project Team	
Specialist Report	Consultant
Urban Planning	Mecone NSW Pty Ltd
Survey Plan	Total Surveying Solutions
Architectural Plans	Grimshaw Architects
Public Domain / Landscape Concept Plans	Site Image Landscape Architects
Stormwater Concept Plan	Australian Consulting Engineers
Preliminary Geotechnical Investigation Report	El Australia
Traffic Impact Assessment	Traffix
Daylight Analysis	LCI Consultants
Services Design Brief	LCI Consultants
Public Art Strategy	Site Image Public Art Consultants
Noise Impact Assessment	White Noise Acoustics
Heritage Impact Assessment	Weir Phillips
Historical Archeological Assessment	Austral Archeology
Wind Assessment	Wind Tech
Economic Impact Assessment	HillPDA Consulting
Supply and Demand Analysis	SMA Tourism
Flood Certification Assessment	Australian Consulting Engineers

1.2 Relevant Development Applications

On 23 October 2017, Council granted consent to a Development Application on behalf of Samprian.

The consent provides approval for the construction of a 15 storey hotel building reaching a compliant height of 50m that adaptively reuses the Sutton Forest Meat building through the demolition of all non-significant interior fabric and retention of the heritage significant façades. The development's approved use relates to a hotel containing 174 rooms.

The approval permits a zero metre setback to the northern boundary that interfaces with the residential flat building known as 'Capitol Terrace' apartments for the full height of the building. Above the street frontage, the tower provides a 10m setback to the southern boundary fronting Valentine Street; however, from Level 8 to 14 this setback reduces to 8m, permitting the tower element to cantilever over the heritage item.

The approved floor plans and setbacks are shown below from **Figures 1 – 2**.



Figure 1 Approved Setbacks Above the Street Frontage (Levels 3 - 4)

Source: Barker Kavanagh Architects



Figure 2 Approved Setbacks Above the Street Frontage (Levels 8 – 13)
 Source: Barker Kavanagh Architects

2 Site Context and Description

2.1 Site Analysis

The site is located at 757 – 759 and 761 – 763 George Street, Haymarket within the City of Sydney Local Government Area (LGA).

The site is located on the south western fringe of Sydney Central Business District (CBD) on a corner block bounded by Valentine Street to the south and George Street to the east.

The site is positioned 300m to the north west of Central Station. Being located adjacent to a major transport interchange it is afforded ample access to public transport.

The site is strategically positioned within a locality earmarked to undergo significant transformation. Under the Draft CSPP, the site is positioned within a Tower Cluster Area where sites have the potential to achieve substantial increases in density.

The site is also located to the direct west of the Western Gateway Sub-precinct, which forms part of the broader Central Precinct. The Western Gateway Sub-precinct is earmarked to emerge as the focal point of Sydney's Innovation and Technology Precinct and will serve as a mixed-use innovation hub anchored by high-tech firms, educational institutions and startups.

The site's locational context is shown from **Figures 3 – 4**.

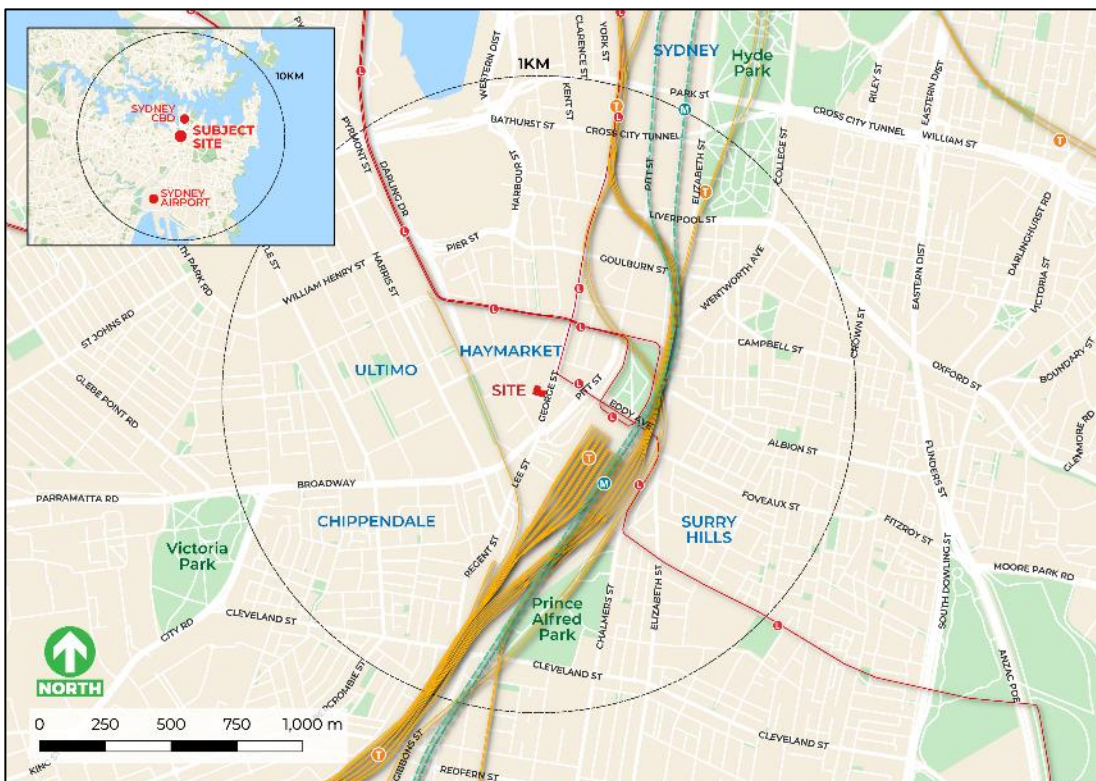

Figure 3 Context Map
Source: Mecone / Mosaic

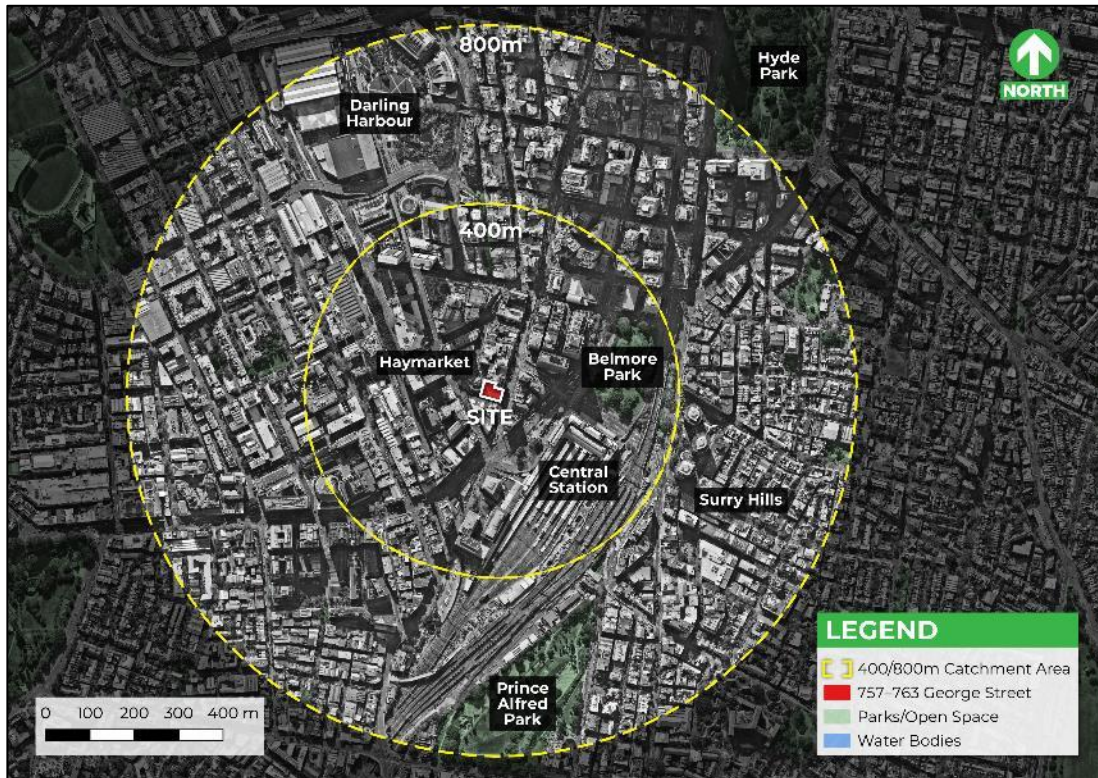

Figure 4 Context Aerial Site Map
 Source: Mecone / Mosaic

2.2 Legal Description and Ownership

The site comprises two allotments which combined have an area of 1,030m².

The table below provides the address, legal description and existing development details of the site's allotments.

A Survey Plan is included at **Appendix 1**.

Table 2 – Property Description(s)				
Address	Lot	DP	Owner	Site Description
757 – 759 George Street	11	70261	Sampran	Four (4) storey mid-century mixed use commercial building and open car park.
761 – 763 George Street	1	1031645	Sampran	Two (2) storey mixed use building known as the 'Sutton Forest Meat' Building, which occupies the whole lot and is a locally listed heritage item.

2.3 Site Description

The existing development contained within the site consists of two commercial buildings. The building located at 757 – 759 George Street reaches four (4) storeys in height. The upper storey is recessed from the building parapet to provide a three (3) storey appearance when viewed from street level. The building is subject to a fire order and consequently cannot be occupied.

The site's corner building located at 761 – 763 George Street accommodates a two (2) storey brick building with decorative elements.

The northern boundary of the site is subject to a shared easement associated with a right of carriage way for a vehicular access driveway which permits access to an open carpark at the north western boundary.

This building is also subject to a fire order which prevents the use and occupation of second storey above ground.

A site aerial map is shown at **Figure 5**. Photos of the existing development are shown from **Figures 6 – 8**.

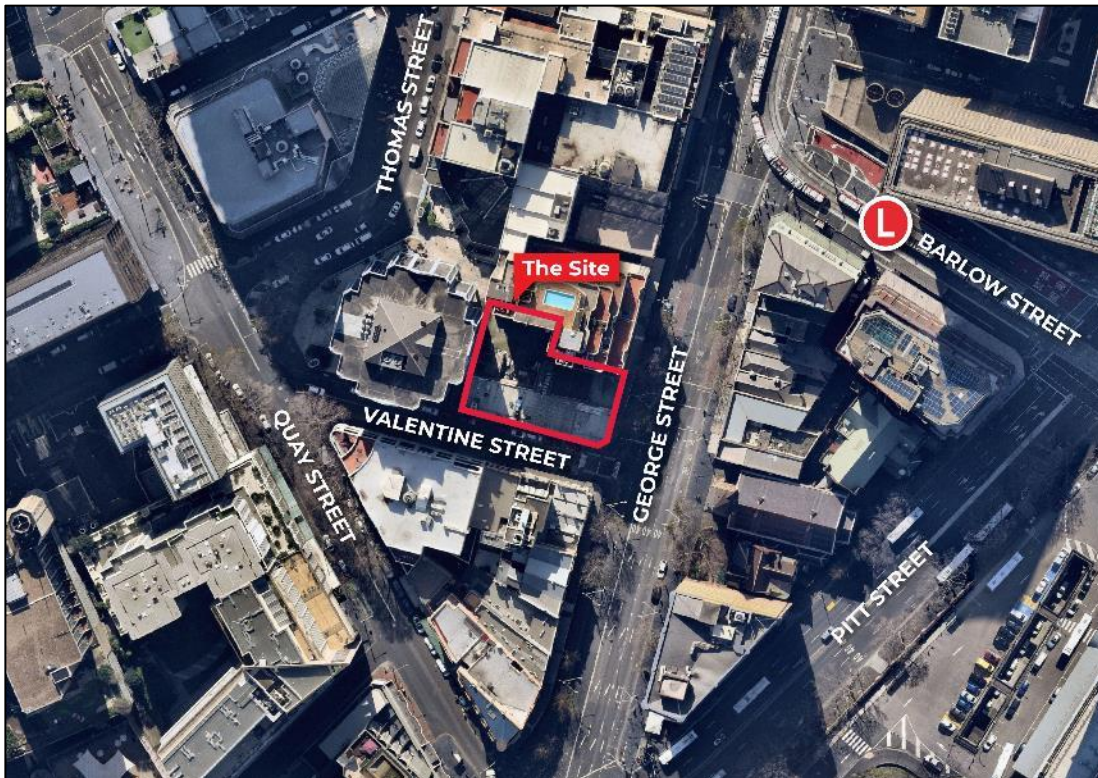

Figure 5 Site Aerial Map
Source: Mecone / Mosaic



Figure 6 Site Viewed Looking North West from George Street
Source: Mecone



Figure 7 Heritage Listed Building at 761 – 763 George Street Viewed Looking North
Source: Mecone

The table below provides a more detailed summary of the site and surrounding context.

Table 3 – Site Description	
Item	Description
Legal Description:	<ul style="list-style-type: none"> • Lot 1 in DP 1031645; and • Lot 11 in DP 7026
Total Area	1,030m ²
Site description and street frontage	19.11m to George Street (eastern frontage); and 38.70m to Valentine Street (southern frontage).
Site topography	The topography of the site falls from south to north 1.26m (RL12.28 – RL11.02) along the George Street frontage. The frontage along Valentine Street falls from west to east 0.5m (RL12.74 – RL12.28).
Access	Direct access to the buildings contained within the site is afforded from George Street via separate individual entrances.
Access to Public Transport	The site receives ample access to public transport. It is located 150m (2 min walk) south west of the Haymarket (Rawson Place) light rail stop which forms part of the CBD and South East Light Rail Network and provides connections to Circular Quay and Kingsford. It is positioned 300m to the west of Central Station Transport Interchange which provides a range of metro and regional train connections and will form part of the future Sydney Metro network. It is located 300m of Railway Square Interchange which supports a range of bus services that provide connections to Greater Sydney.

2.3.1 Heritage

The site is not located within a heritage conservation area but does contain a heritage item. The corner building located at 761 - 763 George Street is a locally listed heritage item (I843) known as the '*Former Sutton Forest Meat Building*'. It is significant for its historical associations and its rare aesthetic qualities.

Its facades fronting George and Valentine streets are the only structures of heritage significance. The remaining interiors have been subject to extensive fire damage, significantly altered and/or approved for removal under DA/2017/353.

As shown in **Figure 8**, the site is also located in the vicinity of a number of heritage items. Notable items in the immediate vicinity include:

- 1844 - 767-769 George Street, Haymarket – '*Local heritage commercial building group*';
- 1848 - 814 George Street Haymarket - *Local heritage item 'Former Lotteries Office*'; and

- 1849 - 812B George Street, Haymarket and 505 Pitt Street, Haymarket - State Heritage Item 'Christ Church St Laurence Group'.

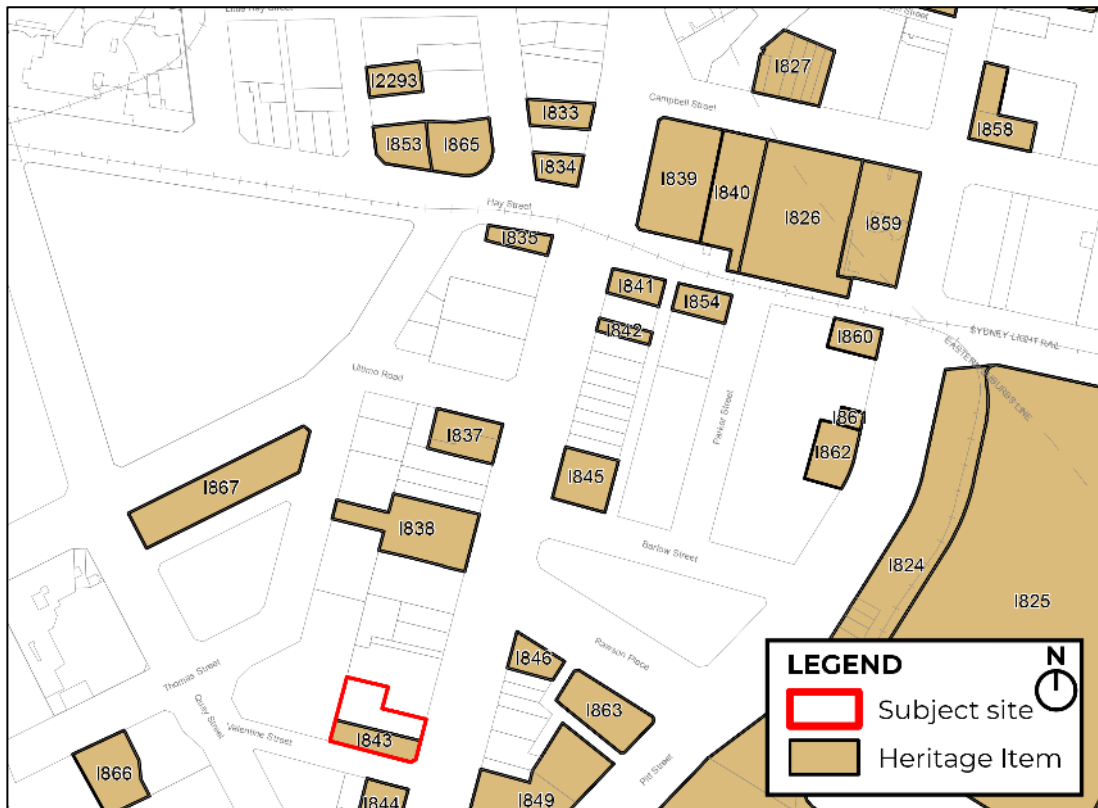

Figure 8 Site and Surrounding Heritage Items
 Source: Mecone / SLEP 2012 – Sheet 15 Heritage Map

2.4 Surrounding Development

The site is located within the Haymarket/Chinatown Special Character Area under the SDCP 2012. The surrounding development consists of a mix of commercial, retail and educational uses.

The surrounding development consists of the following:

North

To the immediate north the site adjoins a 13 storey residential flat building known as 'Capitol Terrace' which is separated from the proposal by the site's vehicular access driveway. The western end of its southern elevation comprises a blank facade and is setback from the common boundary. The eastern portion of its southern elevation provides a nil setback to the common boundary and accommodates windows in limited locations.

South

The development to the immediate south on the opposite side of Valentine Street consists of fine-grained brick masonry buildings that range in height from two (2) to three (3) storeys.

East

To the immediate east the site is bounded by George Street which consists of a six (6) landed carriageway. Further eastward adjacent to the intersection of George and Valentine Street lies Christ Church St. Laurence located at 814A George Street which is a locally listed heritage item (1849). Adjoining this building to the south east is another locally listed heritage item known as the 'Former Lotteries Office' which comprises an eight (8) storey brick building.

Beyond this lies Central Station Transport Interchange and Railway Square Interchange. The Haymarket Light Rail Station is located 150m to the north east adjacent to Rawson Place.

West

The development to the direct west located at 187 – 189 reaches to storeys and accommodates two (2) levels of basement parking. The development is built to the eastern common boundary and directly interfaces with the site. Its eastern façade comprises a blank wall. The site is subject to a Planning Proposal to facilitate a 48 storey mixed use tower (refer to **Section 2.5**).

The surrounding development is illustrated from **Figures 9 - 11**.



Figure 9 View of Christ Church St. Laurence Looking East Down Valentine Street
Source: Mecone



Figure 10 Fine-Grained Retail Uses Along George Street Looking North East
Source: Mecone



Figure 11 High Rise Developments Viewed From Valentine Street Looking West
Source: Mecone

2.5 Future Development Context

2.5.1 Haymarket/Ultimo Tower Cluster Area

The Draft CSPA designates the site as forming part of the Ultimo/Haymarket Tower Cluster Area, as shown in the figure below. The Draft CSPA affords sites within the Tower Cluster Area the opportunity to unlock additional capacity for economic and employment growth.

Following the implementation of the CSPA, the future development context will undergo a process of transformation and will emerge to consist of large-scale towers reaching unprecedented heights.



Figure 12 Site's Location within the Haymarket / Ultimo Tower Cluster Area

Source: Grimshaw

2.5.2 187 Thomas Street Planning Proposal

A Planning Proposal for the adjoining property to the immediate west at 187 Thomas Street was recently supported by Council at the Ordinary Meeting held 21 September 2020 to progress to Gateway Determination.

The Planning Proposal requests amendments to the SLEP 2012 to facilitate the delivery of a preferred tower scheme within the parameters of a DCP Envelope that is shown in **Figure 13**. This DCP Envelope comprises:

- A maximum FSR of 25:1 (with the Preferred Scheme's FSR limited to 20:1 above ground) including design excellence;
- Floor space of 1.5:1 for uses below ground level;
- RL 226.80 (216.4m above ground level);
- A podium height of 14m to align with the subject site's heritage building;

- Non-compliant setbacks, including:
 - A nil northern setback from the podium to the property at 191 Thomas Street that increases to a maximum of 3m at the tower element;
 - A 4.8m setback to Thomas / Quay Streets at the ground plane that increases to 10m at the tower element;
 - A nil western setback to Thomas Street; and
 - A setback ranging from 1 – 5m to the eastern boundary that interfaces with the subject site.

The setbacks are supported due to the scheme's compliance with the variation testing procedure set out in Procedure B, Schedule 11 of the Draft CSPS.

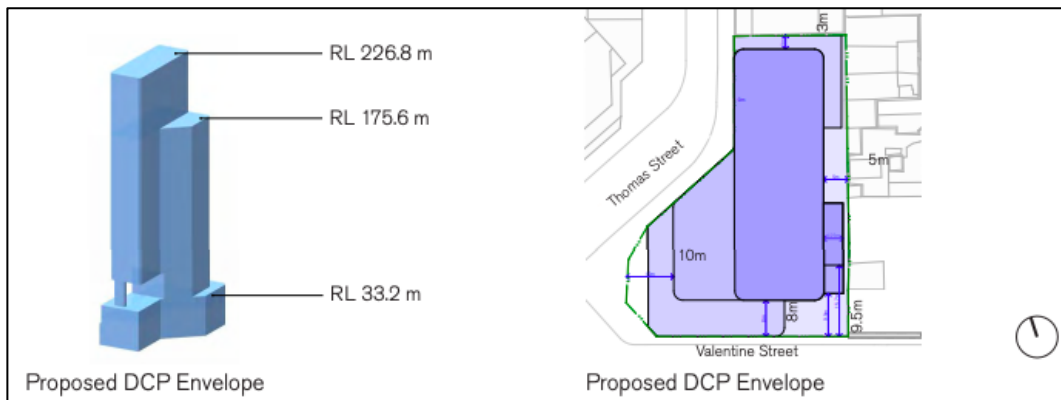

Figure 13 DCP Envelope for 187 Thomas Street Viewed Looking South West
Source: *fjmt*

The base case envelope relied upon for the variation testing procedure has a podium height of 25m (refer to **Figure 14**), which represents a non-compliance with the Schedule 11 exhibited alongside the Draft CSPS between May to March 2020 concurrent with Council's assessment of the Planning Proposal (lodged in April 2020) and prior to Council's making of their own Planning Proposal for the site (dated September 2020).

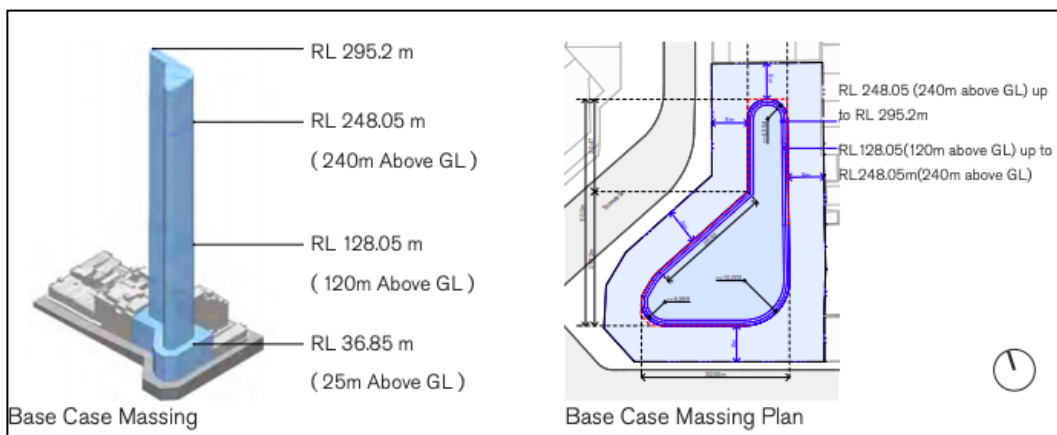

Figure 14 Base Case Envelope for 187 Thomas Street Viewed Looking North East
Source: *fjmt*

As established by Procedure B and the referenced *Table 5.3 - Minimum Street Frontage Heights in Special Character Areas of the Draft Sydney Development Control Plan – Central Sydney 2012 (Draft DCP)*, the base case envelope's podium is required to provide a street frontage height that aligns with the height of the nearest heritage item on the same side of the street.

The Sutton Forest Meat Building contained within the site adjoins 187 Thomas Street and is therefore the nearest heritage item. It has a street frontage height of approximately 14m. Accordingly, the podium of the base case envelope for 187 Thomas Street is required to reach 14m as opposed to 25m to align with this heritage item.

In addition, the base case envelope has a maximum height of 295m which encroaches into the non-developable construction zone above the maximum height limit of RL 285m, representing a non-compliance with Schedule 11 of the Draft DCP.

2.5.3 Central State Significant Precinct

To the east of this Tower Cluster Area, lies Central Precinct which covers 24 hectares of land and comprises a number of sub-precincts which are earmarked to be redeveloped to support the emergence of the Sydney Innovation and Technology Precinct. The site is located a short 250m from the Western Gateway sub-precinct.

This sub-precinct was recently rezoned in August 2020 to permit tower developments of unprecedented heights. Specifically, the amended planning controls for the precinct permit the following:

- 14 – 30 Lee Street, Haymarket (Railway Square YHA Site) – A commercial tower with 70,000m² of GFA and a maximum height of RL 200.2.
- 8 – 10 Lee Street, Haymarket (Henry Dean office block) – Two commercial towers with 50,000m² and 40,000m² of GFA and a maximum height of RL 205.8m.

In addition to the above, the site at 2 – 6 Lee Street (Adina Hotel Site / Henry Deane Plaza) is also earmarked to support a tower development of a similar scale to those listed above and will be redeveloped under a separate planning and design process.

The indicative location of the towers and 187 Thomas Street is shown in **Figure 15**.



Figure 15 Indicative Location of Future Towers
Source: Grimshaw

2.6 Planning Context

The strategic planning framework situates the site within several strategically significant precincts, as shown in **Figure 16**. The planning priorities associated with these precincts identify the need to prioritise employment generating uses and foster the growth of target industry sectors, including the visitor economy, to ensure Sydney remains an attractive place for businesses and leisure visitors.

A detailed discussion of the applicable local and regional strategic planning policies is provided below.



Figure 16 The Site's Strategic Context
 Source: Mecone / Mosaic

2.6.1 Regional Planning Context

The site is positioned on the south western edge of the Harbour CBD which is identified by the *Greater Sydney Region Plan – A Metropolis of Three Cities* (the Greater Sydney Region Plan) as Australia's global gateway and financial capital.

Within the Harbour CBD, the site forms part of the emerging Innovation Corridor. Extending from The Bays Precinct to Royal Prince Alfred Hospital, the Innovation Corridor is earmarked to accommodate international innovation companies, universities and start-ups.

The Greater Sydney Region Plan forecasts that there will be a shortage of office floor space. To support the continued emergence of the Innovation Corridor, it notes that a flexible approach to the application of the Planning Controls is required. To facilitate this, the Greater Sydney Region Plan identifies a need to maximise vertical development opportunities. Southern Central Sydney, particularly the portion encompassing the Innovation Corridor along the Redfern to Eveleigh corridor to which the site relates, is noted as being suitable for additional height and density.

The importance of the Innovation Corridor is recognised by the Eastern City District Plan (District Plan) which guides the implementation of the Greater Sydney Region Plan at a district level. The Plan notes that the Innovation Corridor should continue to support the growth of the economy through the contribution of jobs in creative, digital and business support services.

The growth of the workforce will produce a corresponding demand for visitor accommodation that is necessary to support the needs of the business community and leisure visitors. The District Plan identifies that the visitor economy contributed over \$8.6 billion to its economy. In light of this, it nominates the Planning Priority to continue to enhance the tourism and visitor sector via a coordinated approach to accommodation, events and tourist related activities.

To deliver on the planning objectives for the Eastern District and to support the growth of the Innovation Corridor, the NSW Government in August 2018 announced its commitment to investing \$48.2 million to establish a globally competitive technology precinct formally known as the Sydney Innovation and Technology Precinct. The site forms part of the Sydney Innovation and Technology Precinct, with this precinct also encompassing Central Precinct.

In December 2018, the NSW Government published the *Sydney Innovation and Technology Precinct Panel Report* which outline a number of recommendations to support the emergence of the Sydney Innovation and Technology Precinct. Specifically, it nominated a target of 250,000sqm of net lettable floorspace for technology and innovation companies. It also recommended that additional floor space also target the short term accommodation needs of the precinct and its companies, institutions and organisations.

In July 2019, the Central Precinct was declared Nominated SSP by the Minister for Planning and Public Spaces. The Western Gateway sub-precinct is one of 10 sub-precincts across Central Precinct to be subject to plans for redevelopment to facilitate the emergence of the Sydney Innovation and Technology Precinct. The recently gazetted LEP amendments for the precinct allow for the achievement of unprecedented heights and once developed will be a drawcard for innovation companies and start-ups.

The site is strategically located approximately 250m to the west of the Western Gateway sub-precinct and as noted above is within the broader future Sydney Innovation and Technology Precinct. The site's strategic positioning provides the opportunity to deliver hotel accommodation that will support future businesses and foster agglomeration benefits.

2.6.2 Local Planning Context

The proposed LEP amendments have been prepared under the guise of the *Draft Central Sydney Planning Strategy* (Draft CSPS) and associated Draft DCP.

The Draft CSPS provides a 20 year growth strategy for Central Sydney. Its proposed controls are intended to unlock economic opportunities and increase the supply of employment generating floorspace by maximising development capacity and delivering 2.9 million sqm of new floor space. Under the Draft CSPS, growth is targeted in four new Tower Cluster Areas. The key mechanisms for encouraging growth in these areas are as follows:

- Permit towers with significantly greater heights determined with reference to the No Additional Overshadowing (NAO) controls, solar access planes and the airspace restrictions;
- Priorities mixed use development by limiting the supply of residential accommodation;
- Encourage innovative designs that priorities environmental sustainability and provide attractive spaces for prospective tenants; and
- Introduce a streamlined DA approval process pursuant to subclause 6.21(7A) of the SLEP 2012 for Tower Cluster Area sites.

The Draft CSPS situates the site within the Haymarket / Ultimo Tower Cluster Area. It is envisaged that growth in the Tower Cluster Area will align with the planned investment in physical infrastructure, including the planned Sydney Metro and upgrades to Central Station.

The Draft CSPS prescribes a range of objectives and actions which provide an impetus for the proposed LEP amendments. In particular, it nominates the need to provide an appropriate mix of land uses that will promote Central Sydney's visitor and night-time economies to maintain its role as a leading metropolitan centre. It also strengthens the incentive for hotel accommodation and removes the incentives for residential and serviced apartment floorspace.

The aspirations of the Draft CSPS are reflected in the *City Plan 2036 – Local Strategic Planning Statement* (the LSPS) which highlights the need for Sydney to remain a drawcard for tourists by unlocking new sites for a diverse range of hotel accommodation types. In light of this, the LSPS establishes that the demand for hotels is projected to grow by 4.7% annually to 2020. It notes that whilst there is a large supply of high-end hotel accommodation concentrated within Central Sydney, there is a growing need for mid-range accommodation that will assist in diversifying hotel accommodation types to cater to the needs of visitors in localities that experience high levels of visitation. In light of this, the Draft CSPS identifies the need to unlock new sites for hotel accommodation using a place-based approach that respects local character and preserves Sydney's status as a premier tourist destination.

3 Key Current Planning Controls

3.1 Sydney Local Environmental Plan 2012

The SLEP 2012 is the principal local Environmental Planning Instrument (EPI) applying to the site. The provisions of the SLEP 2012 and the key development controls that apply to the site are outlined below.

3.1.1 Zoning

The land subject to the Planning Proposal is currently zoned *B8 Metropolitan Centre* under the SLEP2012 (refer to **Figure 17**). The proposed uses including commercial, retail and hotel are permissible with consent in this zone. The planning Proposal does not seek to change this land use zone.

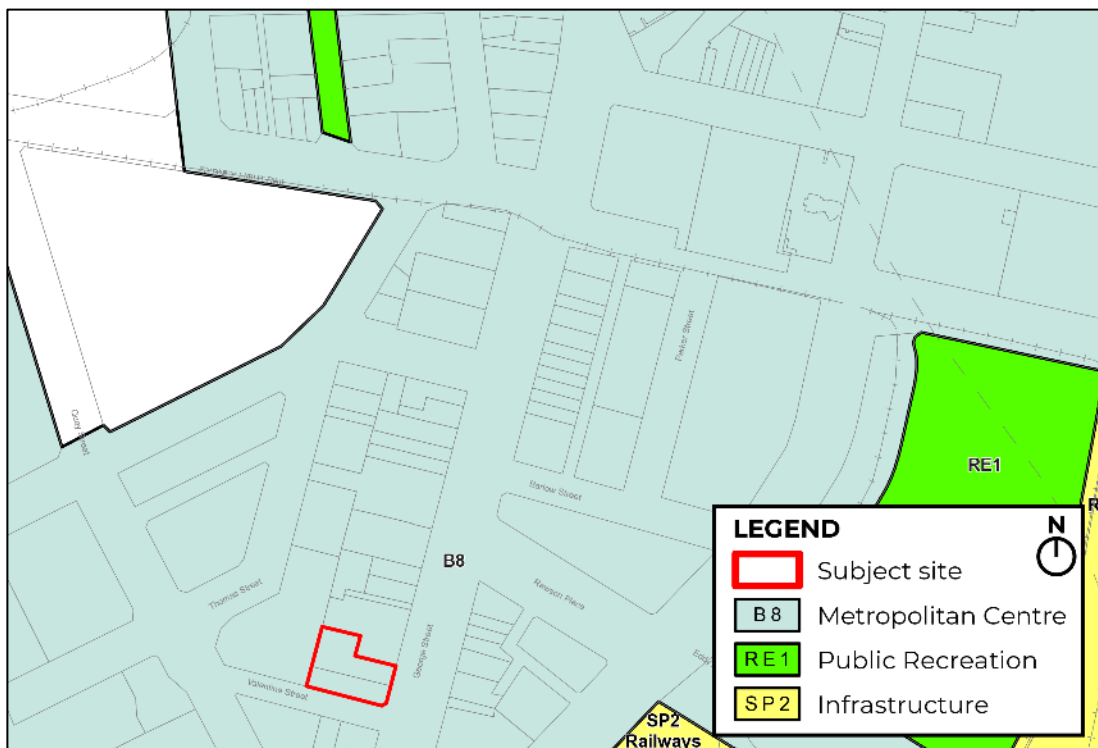

Figure 17 Land Zoning Map
Source: SLEP 2012 – Sheet 15 Land Zoning Map

3.1.2 Building Height

The applicable Maximum Height of Buildings Development Standard prescribed by the SLEP 2012 nominates a height limit of 50m for the site.

Figure 18 provides an extract from the Height of Buildings map showing the height controls for the site and those in the vicinity.

Pursuant to clause 6.21 of the SLEP 2012, the site is eligible for an additional 10% height (or FSR) bonus for design excellence.



Figure 18 Existing Height of Buildings Map
 Source: Mecone / SLEP 2012.- Sheet 15 Height Map

3.1.3 Floor Space Ratio

The applicable FSR Development Standard prescribed by the SLEP 2012 nominates a maximum FSR of 7.5:1 for the site.

Pursuant to Clause 6.4 of the SLEP 2012, the site is located within Area 4 and is therefore eligible for a bonus FSR of 1.5:1 for residential accommodation, serviced apartments, hotel or motel accommodation, community facilities or centre-based child care facilities.

Pursuant to clause 6.21 of the SLEP 2012 the site is also eligible for an additional 10% FSR (or height) for design excellence.

In addition, an additional FSR up to 0.3:1 for *end of journey floor space* is also available pursuant to Clause 6.6 of the SLEP 2012.

Figure 19 provides an extract from the SLEP 2012 showing the FSR maximum for the site and those in the vicinity



Figure 19 Existing Floor Space Ratio Map
 Source: Mecone / SLEP 2012.- Sheet 15 FSR Map

3.2 Sydney Development Control Plan 2012

The site is subject to the SDCP 2012 and its detailed built form provisions. The SDCP 2012 situates the site within the Haymarket / Chinatown Special Character Area.

The SDCP 2012 notes that the Haymarket / Chinatown Special Character Area is typified by a fine grained subdivision pattern, narrow frontages, low street wall and generally low building heights. It prescribes a number of principles that are to inform the design of future developments. These include:

- *Development must achieve and satisfy the outcomes expressed in the character statement and supporting principles;*
- *Retail and enhance the urban character and scale of the Haymarket locality by requiring new buildings to:*
 - *Be built to the street alignment;*
 - *Have street frontage heights consistent with the prevailing form of heritage items in this Special Character Area; and*
 - *Have building setbacks above those street frontage heights;*
- *Maintain a high level of daylight access to the street by restricting building height and bulk;*

- *Recognise and enhance the diversity of uses in the area;*
- *Maintain and reinforce permeability within the area and the intricacy of the urban fabric by retaining the existing significant lanes, original street pattern, special corner treatment, small allotments and narrow frontages, and encourage through site links;*
- *Reinforce the distinct topography of the area by maintaining the layering of development when viewed from Darling Harbour and the City's higher buildings in the background;*
- *New development is to maintain and enhance vistas within the area to Darling Harbour;*
- *New development is to maintain and enhance vistas east along Valentine Street to Christ Church St. Laurence at 814A George Street, Haymarket;*
- *Maintain and enhance the existing vista to the Anglican Christ Church of St Laurence along Valentine Street; and*
- *Facilitate the activation of Douglass Street and Douglass Lane and Eagar Street & Eagar Lane for increased public use.*

In addition to the above principles, the SDCP 2012 applies a range of controls to govern the future built form.

Notable controls include the requirement for a 15m street frontage height or the height of the nearest heritage item on the same side of the street to achieve a consistent building alignment. Setback alignments, including rear, are to be consistent adjoining buildings. Setbacks above the street frontage for non-residential uses are to be included if adjacent buildings include upper level setbacks or if adjacent to a heritage item.

It is noted that many of the detailed built form controls nominated by the SDCP 2012 controls are to be superseded by the proposed Draft DCP.

4 Indicative Development Context

4.1 Overview of Preferred Scheme

The Planning Proposal is supported by a Preferred Scheme prepared by Grimshaw. The Preferred Scheme represents an indicative design concept that reflects the built form potential capable of being delivered within the parameters of the proposed amendments to the planning controls.

The Preferred Scheme comprises the following:

- Demolition of the existing building located at 757 – 759 George Street;
- Adaptive reuse of the heritage listed building located at 761 – 763 George Street and demolition of its non-significant fabric;
- Construction of a 30 storey mixed use hotel building with a gross floor area of 12,318m² (FSR 12:1) above ground comprising:
 - A maximum height of RL 117.87 or 105.87m measured from ground level;
 - 280 hotel rooms of a 3.5-star grade;
 - 1,523m² of hotel amenity rooms;
 - A podium containing 171m² of retail floor space;
- Construction of two (2) level basement accessible from Valentine Street, comprising:
 - Seven (7) valet vehicle spaces accessible from a car lift;
 - End-of-trip facilities;
 - Back of house facilities, services and plant;
 - Bike Storage; and
- Public domain upgrades and the potential for a through-site link along the northern boundary.

Preferred Scheme is illustrated in the Architectural Design Report prepared by Grimshaw at **Appendix 2** and in the figure below.



Figure 20 Preferred Scheme Viewed South (Above) and West (Below)
Source: Grimshaw

4.1.1 Urban Design

The following urban design considerations have informed the development of the Preferred Scheme:

- **Heritage Revitalisation:** The site is located within the Haymarket / Chinatown Special Character Area and the proposal has sought to conserve and enhance the character of the locality by adaptively reusing the Sutton Forest Meat Building contained within the site;
- **Public Domain Upgrades:** The proposal provides the opportunity to deliver a through-site link and contribute the revitalisation of the ground plane, which will complement Council's envisaged public domain upgrades for the locality and wider Central Square;
- **Activation:** The proposal has sought to maximise the provision of active frontages along George and Valentine streets to reinvigorate the public domain in anticipation of their conversion to shareways;
- **Protection of Public Places:** In designing the proposal, due consideration has been given to ensuring the envelope provides improved or equivalent wind and solar impacts to public places and is suitably scaled to prevent overshadowing to significant places;
- **View Corridors:** The siting of the tower has sought to maintain and enhance vistas along Valentine and George streets to Christ Church Saint Laurence; and
- **Environment Sustainability:** The proposal has sought to facilitate an envelope capable of adopting best practice sustainability measures at the detailed design phase.

4.1.2 Tower Envelope and Massing

The Preferred Scheme has been developed through careful analysis of the existing historic character and future development opportunity facilitated by the strategic planning framework.

The Preferred Scheme as illustrated at **Appendix 2** proposes a tower reaching 30 storeys in height (excluding roof plant / lift shaft). The tower has a maximum height of RL 117.87 or 105.87m when measured from ground level. The envelope transitions down to RL 115.96 towards the south to provide a varying height. The transition in height ensures the tower is the slimmest at its peak and presents as being a slender building in accordance with built form massing objectives established by the Draft DCP under Section 5.1.1.4.

The tower height has been determined in recognition of the site's relatively smaller area. It provides an intermediate scale compared to the proposed future tower to the east at 187 Thomas Street and the super towers proposed for Central Precinct which reach heights in excess of RL 200m.

The proposed tower envelope is shown in the figure below.

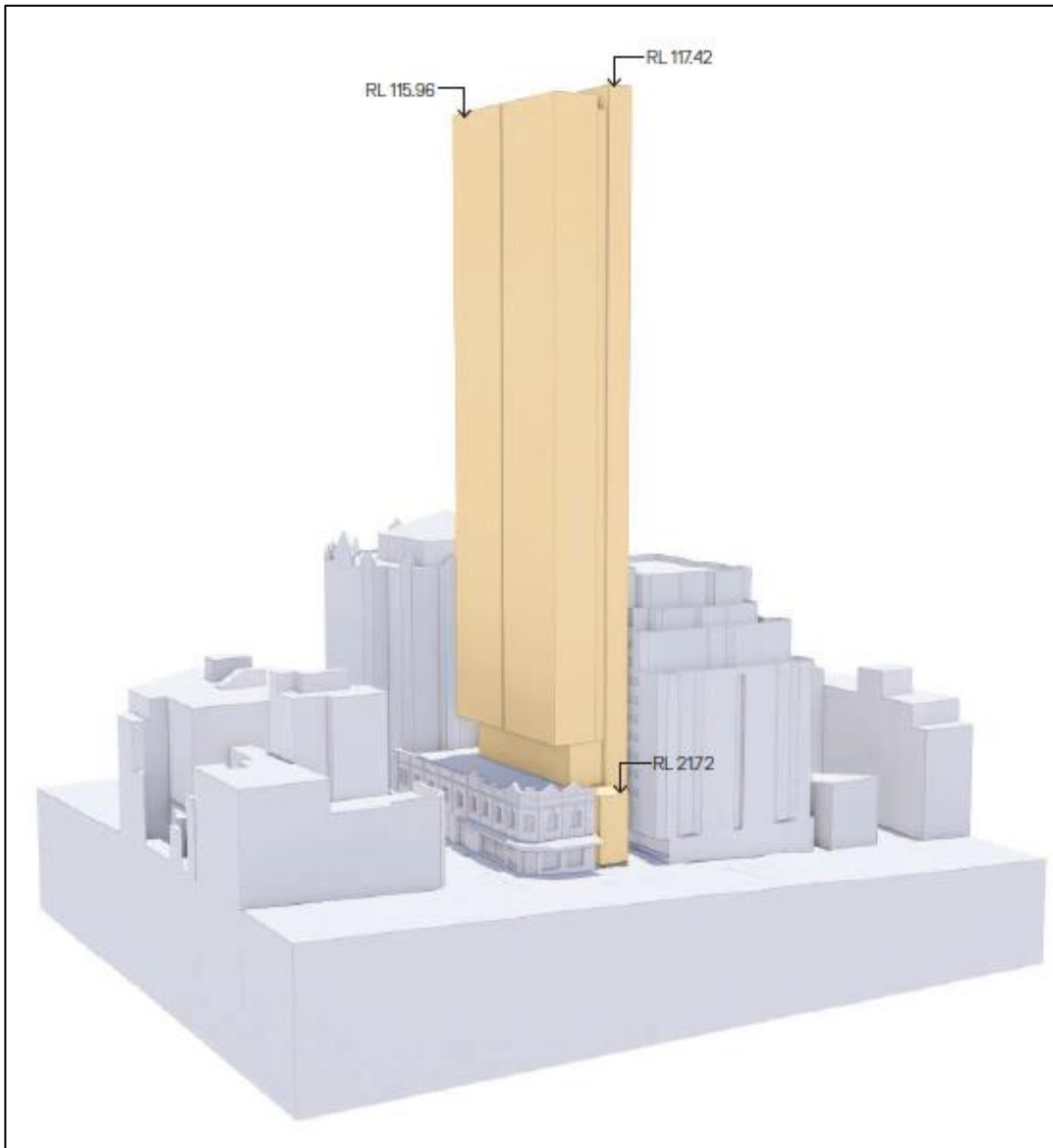

Figure 21 Preferred Scheme Envelope Configuration Viewed Looking North West
 Source: Grimshaw

4.1.3 Podium and Street Frontage Height

The Preferred Scheme incorporates a small podium element that adjoins the heritage listed Sutton Forest Meat Building that occupies the full extent of Valentine Street and the majority of the George Street frontage.

The podium element is visible only from the George Street frontage and aligns with the height of the heritage listed building, as shown in **Figure 22**.

The podium and associated street wall height have been designed to comply with the objectives nominated under Section 5.1.1.2 of the Draft DCP for street frontage heights in Special Character Areas. Specifically, it has been configured so as to reflect the proportions of the heritage building to maintain this building's visual prominence in the streetscape.

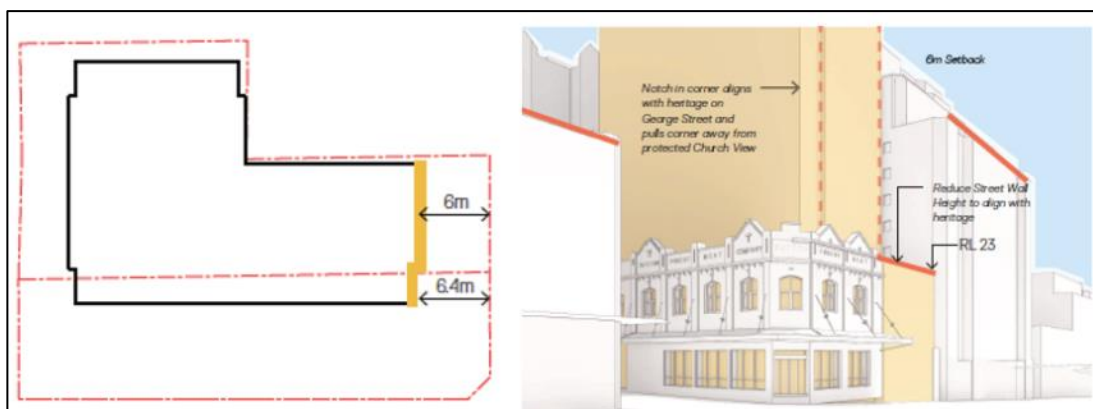

Figure 22 Preferred Scheme's Street Wall Height Viewed from George Street
Source: Grimshaw

4.1.4 Tower Setbacks

The proposed setbacks are illustrated in the figure below and reflect the setbacks for both the Preferred Scheme and DCP Envelope (refer to **Section 4.2** for discussion on DCP Envelope).

The setbacks are proposed in response to the relevant objectives prescribed by the Draft DCP and the site's opportunities and constraints. In summary, the tower setbacks are as follows:

- North (Capitol Terrace Apartments): 0.4m – 1.8m
- South (Valentine Street): 8m
- West (187 Thomas Street): 4m – 4.4m
- East (George Street): 6m – 6.4m

The setbacks for the tower element and the rationale for their inclusion are addressed below.

4.1.4.1 Street Setbacks

The Draft DCP's street setbacks for Special Character Areas outlined in Section 5.1.1.2 are predicated on the need to protect the fabric of heritage items, preserve important view corridors, maintain adequate sunlight and ensure appropriate wind conditions to public places.

The proposal provides a setback of 8m to Valentine Street. The setback has been included to preserve view corridors along Valentine Street towards the heritage listed Christ Church of Saint Laurence and to minimise the amount of built form above the heritage item so as to ensure the cantilevered element is no greater in size than that approved for the site under DA/2017/353.

The proposal provides a setback ranging from 6m to 6.4m to George Street. The increased setback of 6.4m has been provided at the corner to enhance the separation to the heritage item and to allow for its interpretation independent of the tower.

4.1.4.2 Side and Rear Setbacks

The Draft DCP requires that side and rear setbacks ensure sufficient light and air to surrounding public places; promote separation; and avoid the appearance of a contiguous wall of towers.

The proposed tower provides a setback ranging from 4m to 4.4m to the eastern boundary (refer to **Figure 23**). The 4.4m setback exceeds the minimum requirement. It is provided to enhance the proposal's separation to a future development to the east and to protect its redevelopment potential.

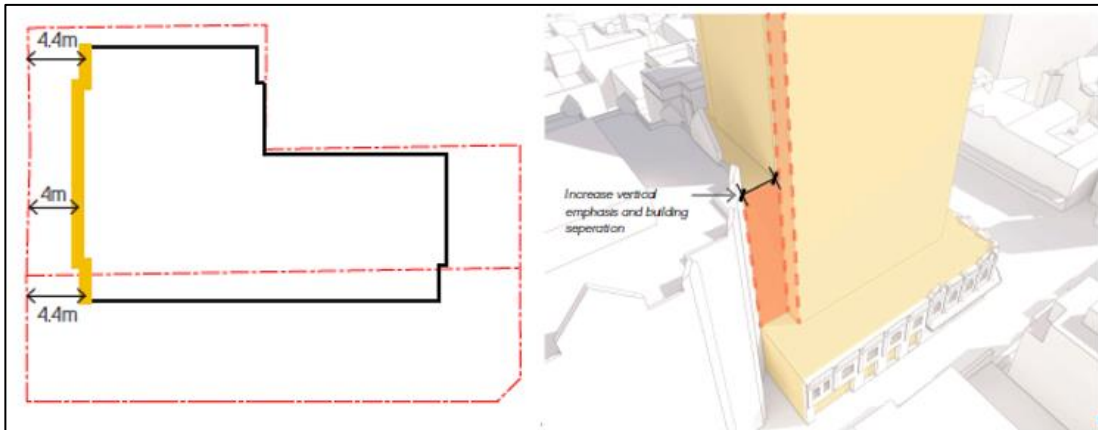

Figure 23 Preferred Scheme's Proposed Eastern Side Setbacks
Source: Grimshaw

The Preferred Scheme provides a northern setback to the site's boundary ranging from 0.4m to 1.8m, as shown in **Figure 24**. The setback represents an increase from the nil setback provided by the tower approved for the site (DA/2017/353). The setback is proposed to ensure a future development provides equivalent amenity impacts to the northern adjoining property relative to the site's approved tower (refer to **Section 9.1.3.1**).

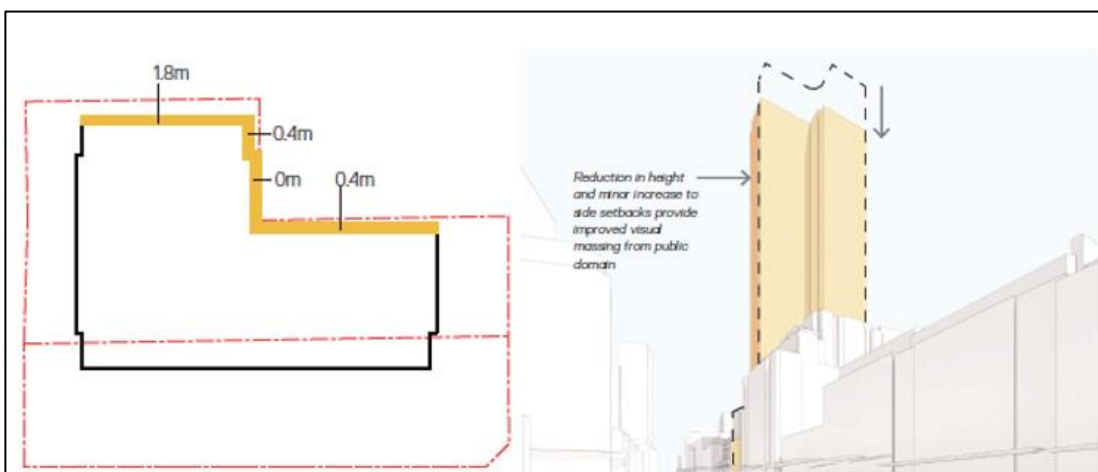

Figure 24 Preferred Scheme's Proposed Northern Setback
Source: Grimshaw

4.1.5 Public Domain and Landscaping

Site Image have prepared a Landscape Concept Design which is included at **Appendix 3**. The public domain treatments and landscaping associated with the Preferred Scheme consist of paving treatments and planters along the northern boundary.

The external terraces located at Level 3 and Level 10 are proposed to incorporate a range of landscape treatments, including perimeter planting with cascading plants and shade tolerate planting.

The proposed landscaping for the terrace areas is shown below.

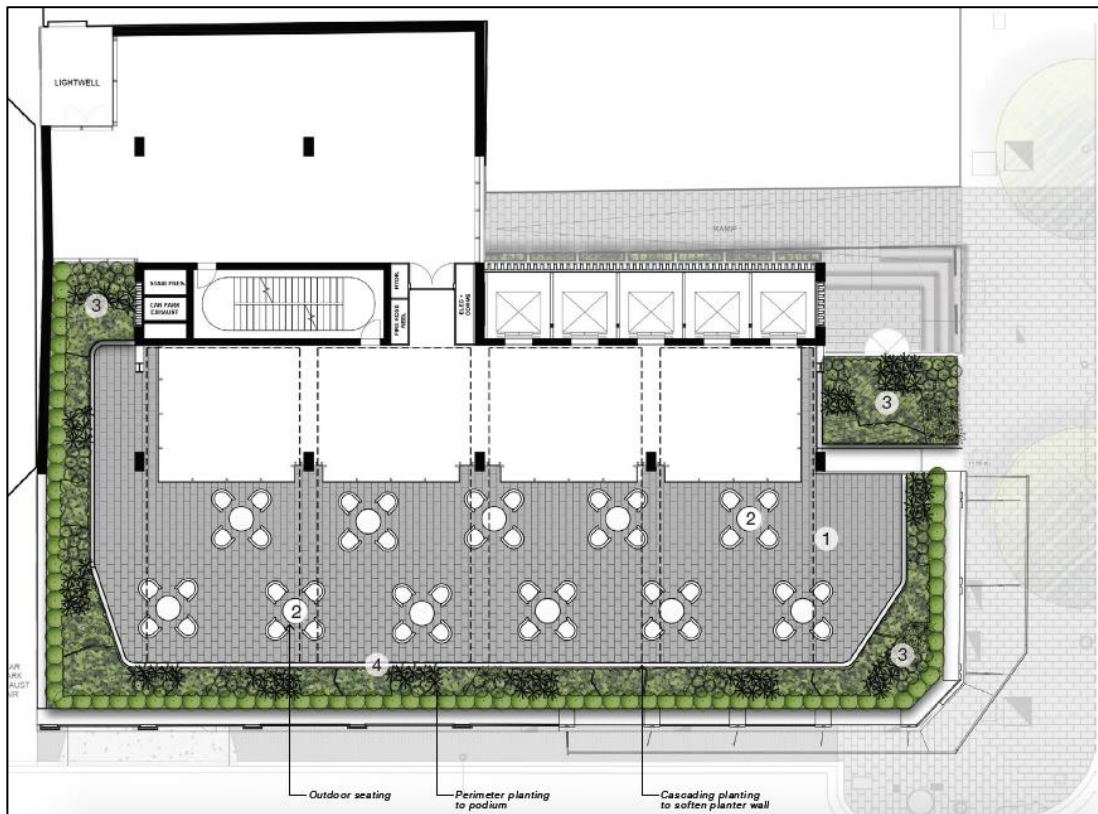

Figure 25 Landscaping Within External Terrace Area (Level 3)

Source: Grimshaw

4.1.6 Uses and Gross Floor Area

The Preferred Scheme proposes a gross floor area (GFA) of 12,318m². With a site area of 1,030m², this amounts to an FSR of 12:1.

The proposal will accommodate retail uses within the podium which is proposed to incorporate and adaptively reuse the heritage item. The tower element is proposed to contain 3.5-star hotel accommodation floorspace with 280 hotel rooms and ancillary hotel amenity rooms.

The distribution of proposed uses is addressed in the table below.

Table 4 – Proposed Uses and Gross Floor Area (Above Ground)

Location	Use	GFAM ²
Podium Levels 1 – 2	<ul style="list-style-type: none"> • Retail • Hotel Lobby 	1642.8
Level 3 / Mezzanine	<ul style="list-style-type: none"> • Hotel Amenity Rooms 	570
Level 4 – Level 11	<ul style="list-style-type: none"> • 3.5-Star Hotel Rooms • 8 Keys Per Level 	3,079
Level 12 – 29	<ul style="list-style-type: none"> • 3.5-Star Hotel Rooms • 12 Keys Per Level 	6,876
Level 30	<ul style="list-style-type: none"> • Hotel Amenity Rooms / Plant 	150
Total Above Ground GFA		12,318

4.1.6.1 Vehicular Access

The Preferred Scheme envisages vehicular access to the loading dock and basement from the western end of Valentine Street to allow for a continuous active frontage (refer to **Figure 26**).

The vehicular entrance is accessible only to staff, service vehicles and hotel valet. It will facilitate direct access to the loading bay and an adjoining car lift. The car lift provides access to seven (7) valet parking spaces accommodated within the lower basement level.



Figure 26 Vehicular Entrance off Valentine Street and Continuous Active Frontage
Source: Grimshaw

4.1.6.2 Pedestrian Access

Pedestrian access to the retail tenancies is permitted via separate entrance points from Valentine Street and the corner of Valentine and George streets.

Pedestrian access to the hotel is proposed via two entrance points, including a primary entrance from Valentine Street adjacent to a taxi drop off area and a secondary entrance from the northern end of George Street.

4.1.7 Public Domain Upgrades

The Preferred Scheme makes provision for a potential through-site link. The through-site link is positioned adjacent to the site's northern boundary and facilitates a potential connection from a future development at 187 Thomas Street through to the Capitol Terrace apartments and its associated arcade. The through-site link provides the opportunity of additional retail activation.

Council's vision for Central Square includes the delivery of a pedestrian friendly spine along George Street and Quay Street. The proposal also provides the opportunity for public domain upgrades at the detailed design phase.

4.2 Proposed DCP Envelope

The proposed DCP Envelope establishes the maximum envelope for the site within the parameters of the proposed LEP amendments. It has a maximum height of RL 117.87 (105.87m from ground) and an FSR of 12:1.

The Preferred Scheme sits wholly within this DCP Envelope and optimises the maximum yield available taking into consideration the requirements of the hotel use and the heritage building, including adequate vertical separation to the tower's cantilevering element.

The DCP Envelope is shown in **Figure 27** and at **Appendix 2**.

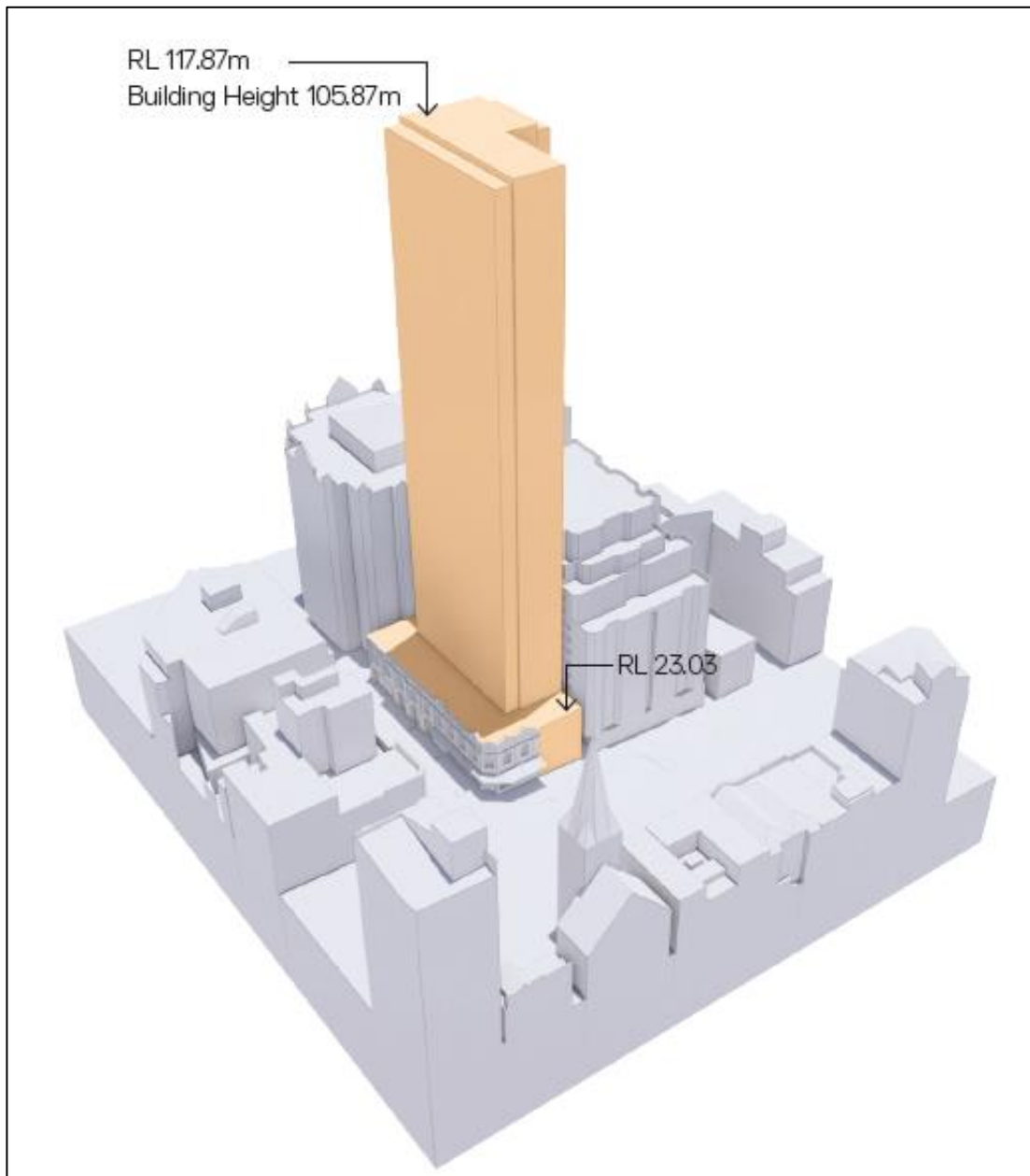

Figure 27 Proposed DCP Envelope

Source: Grimshaw

In designing the DCP Envelope, due consideration has been given to the design excellence requirements established by the Draft DCP's *Tower Cluster Area and Design Excellence Procedure Amendment*. Whilst these provisions are intended for larger sites that meet the minimum 2,000m site area threshold prescribed by the proposed subclause 6.21 (7A), they have been addressed by the DCP Envelope to afford greater flexibility in the design of the scheme at the detailed design competition phase.

Informed by the *Tower Cluster Area and Design Excellence Procedure Amendment*, the DCP Envelope makes provision for the following:

- 15m architectural roof feature zone;

- 5m clear floor to floor for ground and first floors;
- 3.35m floor to floor for typical commercial floors;
- A full floor for every 20 occupied levels at a minimum 6m floor to floor with no floor space;
- 12.5% of the design envelope for architectural articulation;
- 200mm façade depth for an assumed closed cavity façade;
- 16% floor space exclusions allocated to the building core; and
- Vehicle access, servicing, services, balconies, voids and other areas are not to be counted as floorspace.

In addition to the above, the Draft DCP satisfies the equivalence testing requirements established by Schedule 11, Procedure B. Further discussion is provided in **Section 9.4** and **Appendix 2**.

4.3 Design Excellence and Development Options

The Draft DCP's *Tower Cluster Area and Design Excellence Procedure Amendment* requires the development of at least three (3) different and realistic development options that may be explored at the design competition phase. In accordance with this requirement, Grimshaw have prepared alternative envelope options, which are shown below.

Each option is capable of providing a realistic development outcome that complies with the equivalence testing set out in Schedule 11, Procedure B. Further discussion is provided at *Appendix F* of the Architectural Design Report at **Appendix 2**.

5 Planning Proposal Overview

Section 3.33 of the EP&A Act establishes the required contents of a Planning Proposal. The DPIE's *A Guide to Preparing Planning Proposals* (2018) separates these requirements into six distinct parts. These parts are addressed in the proceeding chapters as follows:

- Chapter 6 addresses Part 1 – A statement of the objectives and intended outcomes of the proposed instrument;
- Chapter 7 addresses Part 2 – An explanation of the provisions that are to be included in the proposed instrument;
- Chapter 8 addresses Part 3 – The justification for those objectives, outcomes and process for their implementation;
- Chapter 10 addresses Part 4 – Maps, where relevant, to identify the intent of the Planning Proposal and the area to which it applies;
- Chapter 11 addresses Part 5 – Details of the community consultation that is to be undertaken; and
- Chapter 12 addresses Part 6 – Indicative timeline for the Planning Proposal.

6 Part 1 - Objectives and Intended Outcomes of the Planning Proposal

The Planning Proposal is a site specific amendment to the SLEP 2012 that seeks an alternative height and FSR for the site.

The objectives of the Planning Proposal are to:

- Facilitate the realisation of a mixed-use tower that is taller, slimmer and commensurate in scale with the future built form earmarked for the immediate surrounds and responds to the Draft CSPS's vision for the Haymarket / Ultimo Tower Cluster Area;
- Provide mid-range hotel accommodation to address the growing demand for hotel floor space in a locality anticipated to be redeveloped for large scale commercial towers and which will experience an increase of corporate travelers as a result of the emerging Sydney Innovation and Technology Precinct;
- Provide a mixed-use tower that will deliver on Council's aspiration to increase the supply of employment generating floorspace within Tower Cluster Areas;
- Provide a mix of employment generating uses that will strengthen the economic competitiveness of Central Sydney and provide job opportunities;
- Provide a slender building envelope with an intermediate scale suitable for the size of the site that provides an appropriate transition in scale;
- Provide a scheme with appropriate setbacks that prevent the emergence of a contiguous wall of towers and worsened daylight and pedestrian wind conditions at the ground plane;
- Facilitate upgrades at the ground plane that provide for an improved urban design outcome;
- Facilitate the activation of the surrounding streetscape that is envisaged by Council be converted to shareways by delivering high quality retail uses at street level;
- Optimise the development potential of the site in recognition of its strategic positioning within a Tower Cluster Area and the emerging Sydney Innovation Technology Precinct as well as proximity to Central Precinct;
- Repurpose and adaptively reuse the heritage building contained within the site as a means of protecting the site's heritage values concomitant with delivering a contemporary addition that is compatible with the surrounding future built form;
- Preserve the areas distinct local identity through the retention of the site's heritage significant facades and important view corridors;
- Introduce a contemporary tower element that is sympathetic to the heritage fabric and heritage items in the vicinity of the site;
- Deliver a building envelope that prevents amenity impacts to the adjoining residential property to the north; and
- Amend the applicable planning controls to provide the built form parameters for a future tower capable of exhibiting design excellence.

The intended outcomes of the Planning Proposal are to:

- Amend the existing controls that apply the site which are unduly restrictive, outdated and result in a significant truncation of the height;
- Provide revised planning controls that are appropriate for the site given the future surrounding built form and its location within a Tower Cluster Area;
- Facilitate revised planning controls that align with the objectives and actions proposed by the Draft CSPA and are commensurate with the future controls for surrounding sites;
- Establish a building envelope, along with realistic envelope options that will facilitate an architectural design competition prior to the submission of a detailed Development Application.
- Provide an equivalent residential amenity outcome for the property to the north commensurate with the approved development for the site; and
- Ensure a future detailed Development Application is capable of achieving a high standard of environmental sustainability.

The intended built form outcomes sought under this Planning Proposal are as follows:

Table 5 – Intended Built Form Outcomes		
LEP Provision	Existing	Intended change
Land Use	B8 Metropolitan Centre	No Change
Height	Base LEP height limit of 50m	Increase to 105.87m (RL 117.87m)
FSR	Base LEP FSR limit of 7.5:1	Increase to 12:1 (above ground)

7 Part 2 - Explanation of Amending the LEP Provisions

7.1.1 Amendments to Sydney Local Environmental Plan 2012

The objectives and intended outcomes identified in **Section 6.0** are to be achieved through an amendment to the SLEP 2012.

The amendment consists of the introduction of a site specific clause to Division 5 which establishes the maximum height, FSR and development parameters for the site.

The site specific clause will:

- Allow a maximum building height of RL 117.87m;
- Permit a maximum floor space ratio of 12:1, inclusive of design excellence and additional site specific floor space of 1.61:1;
- Additional floor space of up to 2:1 to be located below ground level for limited purposes to support the related uses in the above ground portion of the building;
- Permit a building that is not used for residential accommodation or serviced apartment uses; and
- Award additional floor space where the development demonstrates design excellence.

7.1.2 Proposed Site Specific Provision

The site specific clause sought by this Planning Proposal for insertion in Division 5 of the SLEP 2012 consists of the following:

6.XX 757 - 763 George Street, Haymarket

(1) The objective of this clause is to encourage:

- (a) land uses other than residential accommodation and serviced apartments,*
- (b) the provision of retail activation and pedestrian connections.*

(2) This clause applies to 757 – 763 George Street, Haymarket, being Lot 11 DP 70261 and Lot 1 DP 103165.

(3) Despite clause 4.3, development consent may be granted to the erection of a building with a maximum height of RL 117.87 metres.

(4) Despite any other provision of this Plan, a building on land to which this clause applies may have a maximum floor space ratio comprising:

- (a) mapped floor space ratio under clause 4.4, and*
- (b) accommodation floor space ratio under clause 6.4, and*
- (c) end of journey floor space under clause 6.6, and*
- (d) an additional site specific floor space ratio of:*

(i) 1.61:1 located in the above ground portion of the building, and
(ii) 2:1 for the purposes of hotel back of house facilities located in the below ground portion of the building as ancillary floor space to support related uses in the above ground portion of the building.

(e) an amount of additional floor space, to be determined by the consent authority, of up to 10% if the building demonstrates design excellence within the meaning of clause 6.21(7)(b).

(5) Clause 4.6 does not apply to development to which this clause applies.

(6) Development consent must not be granted under this clause unless the consent authority is satisfied that the development will –

(a) include business premises and retail premises at street level;

(b) provide a satisfactory distribution of built form and floor space, and

(c) will not be used for the purpose of residential accommodation or serviced apartments.

(7) Clause 6.21(7)(a) does not apply to development on land to which this clause applies.

(8) In this clause –

Hotel back of house means facilities that assist with the operation of the hotel, including office space and housekeeping and are not accessible to guests or the public.

7.1.3 Distribution of Floor Space Ratio

The Planning Proposal will increase the amount of employment generating floor space achievable on the site by permitting a maximum FSR of 12:1, inclusive of the design excellence bonus permitted by clause 6.21(7) of the SLEP 2012.

Specifically, this Planning Proposal provides for additional site specific floor space of 1.61:1 in addition to the base FSR of 7.5:1, accommodation floor space bonus of 1.5:1 and maximum permitted end of journey floor space of 0.3:1. Combined, this results in a proposed FSR of 10.91:1.

When applying the 10% design excellence bonus, the Planning Proposal seeks consent for a maximum floor space ratio of 12:1.

The site specific clause includes an additional floor space of up to 2:1 for floor space below ground level. This ancillary floor space will be restricted to back of house facilities and other ancillary floor space to support related uses in the above ground portion of the building.

A detailed summary of the FSR distribution is provided in the table below.

Table 6 – Application of the Various Floor Space Provisions Under the SLEP 2012

LEP Clause	Applicable Floor Space	Floor Space Ratio
cl. 4.4	Mapped floor space ratio	7.5:1
cl. 4.6	Accommodation floor space	1.5:1
cl. 6.6	End of journey floor space	0.3:1
TBA	Site-specific floor space	1.61:1
<i>Total</i>		<i>10.91:1</i>
cl. 6.21(7)(b)	Additional floor space – design excellence	Up to 10%
<i>Total Above Ground</i>		<i>12:1</i>
TBA	Site-specific floor space – below ground	2:1

7.2 Amendments to the SDCP 2012

A draft Site Specific DCP has been prepared to give effect to the proposed LEP amendments and provide certainty that the future redevelopment of the site will result in an appropriate built form outcome. The proposed draft Site Specific DCP amendment is provided at **Appendix 4**.

8 Justification

8.1 Section A - Need for the Planning Proposal

Q1. Is the planning proposal a result of an endorsed local strategic planning statement, strategic study or report?

The amendments sought by the Planning Proposal and the associated indicative Preferred Scheme are the outcome of extensive design testing undertaken in accordance with the requirements of Procedure B, Schedule 11 of the Draft CSPS and a detailed analysis of the site's opportunities and constraints.

The Planning Proposal has been prepared to facilitate the delivery of a building envelope that is appropriate in the context of the future transformative developments in the immediate surrounds (refer to **Section 2.5**). Additionally, it capitalises on the opportunity to deliver on the strategic objectives nominated by the Draft CSPS by proposing employment generating floorspace and a density commensurate with the site's positioning within a Tower Cluster Area and proximity to existing and planned infrastructure.

Q2. Is the Planning Proposal the best means of achieving the objectives and outcomes, or is there a better way?

Yes, it is considered that the Planning Proposal represents the best means of achieving the objectives and outcomes for the site and realising additional height and employment generating floor space within south Central Sydney.

The proposal has been selected as the Preferred Scheme following a consideration of various design options.

- **Option 1:** Do nothing;
- **Option 2:** Pursue the current scheme approved for the site under DA/2017/353; and
- **Option 3:** Prepare a Planning Proposal to amend the maximum height and FSR development standards to facilitate a tower of a greater height.

Option 1: Do Nothing

Option 1 entails maintaining the site in its existing underdeveloped state. It is noted that both buildings contained within the site are subject to a fire order which sterilises the use and occupation of both buildings to their maximum potential. In light of this, leaving the site in its current undeveloped state represents a missed opportunity to realise its development potential and deliver on the aspirations of the prevailing strategic planning framework.

As discussed in **Section 2.5**, the locality is earmarked to support substantial increases in density and towers reaching unprecedented heights. In particular, the site to the immediate west at 187 Thomas Street is subject to a Planning Proposal to permit heights up to RL 226.80 (216.4m from ground level) whilst surrounding sites in the Tower Cluster Area have the potential to reach heights restricted by the air space controls (in excess of RL 200). When viewed in the context of the surrounding future development, the existing development being only a maximum of 50m (15 storeys) would present as being at odds with the scale of the surrounding built form.

The existing developments contained within the site contribute minimal employment generating floor space. The Economic Impact Assessment prepared by HillPDA Consulting confirms that the existing developments support no more than nine (9) full-time jobs (refer to **Appendix 5**). Further, with the exception of the street facades associated with the corner site, the remaining fabric is not of heritage significance. In light of this, there is little value in retaining the existing built form.

Amendments to the maximum height and FSR are required to facilitate the provision of additional employment generating floor space in alignment with the strategic planning directions for the site. The amendments will facilitate the realisation of a development that adaptively reuses the site's heritage significant fabric, revitalises the site and optimises its development potential to increase employment opportunities for the locality.

Option 2: Pursue the Approved Scheme for the Site

Option 2 entails redeveloping the site in accordance with the existing approval granted under DA/2017/353. The approval provides for the adaptive re-use of the heritage building and the construction of a 15 storey hotel building.

The development of the approved scheme preceded Council's decision to formally exhibit the Draft CSPS. With greater certainty surrounding the status of the Draft CSPS and the future controls for the site and surrounding area, the approved scheme fails to optimise the site's full development potential. Further, being limited to only 15 storeys, it misses the opportunity to maximise the delivery of employment generating floor space within a designated Tower Cluster Area.

Option 3: Planning Proposal for Seeking Additional Height

Option 3 involves the preparation of a Planning Proposal for a tower with a greater height. This option was explored in the preliminary stages of the Planning Proposal's development. The Preferred Scheme's envelope massing comprised a tower with a maximum height in excess of RL 200. The scheme accommodated a mix of 3.5-star and 5-star hotel rooms and sought to vary the setbacks. The rationale for the proposed height was to provide a tower commensurate in scale with proposed developments in the immediate surrounds, including the proposed tower to the immediate west.

A Base Case Envelope associated with this scheme provided a nil non-compliant setback to the northern boundary, as per the approved tower for the site. Based on initial feedback from Council, Option 3 was discounted due to the non-compliances with the base case requirements established by the Draft DCP's Schedule 11. It was determined that a scheme with a reduced height and revised based case would instead be pursued.

8.2 Section B - Relationship to Strategic Planning Framework

Q3. Will the planning proposal give effect to the objectives and actions of the applicable regional, or district plan or strategy (including any exhibited draft plans or strategies)?

a) Does the proposal have strategic merit? Will it:

- Give effect to the relevant region plan outside of the Greater Sydney Region plan outside of the Greater Sydney Region, the relevant district plan within the

Greater Sydney Region, or corridor/precinct plans applying to the site, including any draft regional, district or corridor/precinct plans released for public comment; or

- *Give effect to a relevant local strategic planning statement or strategy that has been endorsed by the Department or required as part of a regional or district plan or local strategic planning statement; or*
- *Responding to a change in circumstances, such as the investment in new infrastructure or changing demographic trends that have not been recognised by existing strategic plans.*

In summary, the Proposal as reflected by the Preferred Scheme and DCP Envelope satisfies the aforementioned requirements and demonstrates strategic merit as it will:

- Support the economic competitiveness of the Harbour CBD and its continued growth;
- Adaptively reuse the site's heritage item to foster the preservation of the locality's heritage and character;
- Encourage investment and jobs growth in the Innovation Corridor;
- Deliver complementary short-term accommodation in proximity to commercial uses, higher education and health related uses accommodated within the Camperdown-Ultimo Heath and Education precinct and within the emerging technology and innovation precinct;
- Provide high quality short-term accommodation that will foster links between business and leisure visits;
- Address the demand for mid-range hotel accommodation in the context of there being an oversupply of high end 5-star hotels;
- Support the productivity objectives nominated by the strategic planning framework by retaining and enhancing the site's commercial activities;
- Respond to a change in circumstances, such as new investment in Sydney's Innovation and Technology Precinct and the need to provide supportive tourism accommodation;
- Encourage investment in the Harbour CBD's visitor economy; and
- Provide no adverse environmental, social or economic impacts.

A detailed discussion regarding the Planning Proposal's consistency with the relevant strategic plans is provided in the sections below.

8.2.1 A Metropolis of Three Cities – The Greater Sydney Region Plan

The Greater Sydney Region Plan was formally adopted by the Greater Sydney Commission in March 2018. It establishes a 40-year vision (to 2056) for Greater Sydney and establishes a 20-year plan to manage growth and change. It aligns land use, transport and infrastructure planning to facilitate Greater Sydney's emergence as a metropolis of three very distinct but connected cities.

The Greater Sydney Region Plan situates the site within the Harbour CBD. It notes that future office supply in the Harbour CBD is limited to approximately 19 years. In consequence, there is a need to maximise vertical development opportunities and the expansion of the CBD, particularly southward along the Central to Eveleigh Corridor. Consistent with the Greater Sydney Region Plan's aspirations, the Planning Proposal provides the opportunity to achieve additional density on the site and contribute to the southward expansion of the CBD.

To achieve the Greater Sydney Regions Plan's overarching vision, it provides a framework consisting of 10 directions and supporting objectives centred around the themes of:

- Infrastructure;
- Liveability;
- Productivity; and
- Sustainability.

The future development facilitated by the Planning Proposal will deliver on the Greater Sydney Region Plan's directions and associated objectives for the reasons set out below:

Specifically, it will:

- *Infrastructure* – The proposal will facilitate jobs growth on the site which will in turn increase patronage of recently delivered and planned transport upgrades, including the Sydney CBD and South East Light Rail, Sydney Metro, Central Walk and the planned upgrades to Central Station.
- *Liveability* – The proposal incorporates active retail use at street level and a potential through-site link that will improve the permeability of south Central Sydney. Further, the proposal relates to the provision of a building envelope with the capacity to accommodate a high quality built form outcome that will positively contribute to the visual amenity of the streetscape. It will foster a socially connected community by delivering needed services such as hotel accommodation and retail uses in walking distance of transport. These uses will address the demands of the growing workforce in southern Central Sydney which is earmarked for economic and employment intensification.
- *Productivity* – Relative the existing development contained within the site, the proposal will increase the supply of employment generating floor space in proximity to existing and planned transport infrastructure, which will contribute to the expansion of the Sydney CBD.
- *Sustainability* – The development facilitated by the Planning Proposal has the capacity to adopt best practice sustainability outcomes at the detailed design phase.

8.2.2 Eastern City District Plan

The Eastern City District Plan (the District Plan) was released by the Greater Sydney Commission in March 2018. It provides a 20-year vision to manage the growth of the Eastern District to achieve the 40-year vision set out by the Greater Sydney Region

Plan. It builds upon the directions and objectives prescribed by the Metropolitan Plan by nominating more detailed planning priorities.

The District Plan identifies that the site occupies a strategically significant location. In particular it forms part of:

- *Harbour CBD* – The District's metropolitan centre which accommodates the largest office market in the region. It is also identified to contain some of the District's most important tourism and major event destinations. The District Plan identifies the need to support the growth of the visitor economy and adopt a coordinated approach to aligning tourism activities, business, events and accommodation.
- *The Innovation Corridor* – The corridor is earmarked by the District Plan to support significant economic growth along with important industries including knowledge intensive, creative and start-up industries as well as health, education and research services.
- *The Southern CBD Precinct* – The precinct is identified as having the most development potential to support the needed expansion of the Sydney CBD's footprint. With the expansion of the CBD and its office market, the District Plan notes that there is a need to promote links between business and leisure visits.
- *Camperdown-Ultimo Health and Education Precinct* – The precinct is identified by the District Plan as integral to supporting changing technologies, knowledge-intensive jobs and is instrumental to delivering on the aspiration to achieve a 30-minute city.

The site's strategic positioning makes it ideally suited to accommodate a mixed-use hotel development. It provides the opportunity to contribute to the expansion of Sydney CBD's footprint by redeveloping an underutilised site and increasing its capacity to contribute employment generating floor space to locality earmarked by the District Plan to support significant economic and jobs growth.

The provision of hotel accommodation will support the growing office market in the surrounds by providing its transient workforce with high quality mid-range hotel accommodation.

By virtue of the site's strategic positioning and its intended uses, the proposal aligns with the detailed Planning Priorities nominated by the District Plan. Further discussion is provided in the table below.

Table 7 – Consistency with the Planning Priorities of the Eastern City District Plan		
Planning Priority		Comment
Planning Priority E6	Creating and renewing great places and local centres and respecting the District's heritage.	<p>The proposed amendments will facilitate the realisation of a built form outcome that exhibits design excellence and contributes to the renewal of the area.</p> <p>The adaptive reuse of the heritage item will protect the character of the area. It will also preserve a heritage item that has important</p>

Table 7 – Consistency with the Planning Priorities of the Eastern City District Plan

		historical associations and positively contributes to the visual amenity and character of the area.
Planning Priority E7	Growing a stronger and more competitive Harbour CBD	By delivering hotel accommodation, the proposal will provide a use that is complementary to the growing office market and emerging innovation and technology precinct.
Planning Priority E8	Growing and investing in health and education precincts and the Innovation Corridor	<p>Relative to the existing development contained within the site, the proposal will substantially increase the supply of employment generating floor space. In turn, it will foster job creation within the Innovation Corridor which is earmarked for economic growth.</p> <p>The site forms part of the Camperdown-Ultimo Health and Education Precinct. The proposal will facilitate job creation and business opportunities within this precinct. Consequently it will support its growth and the diversity of the activities contained within.</p>
Planning Priority E13	Supporting growth of targeted industry sectors.	<p>The Plan identifies tourism is a key economic sector for the Harbour CBD's economy. It identifies the need for continued growth across all of the sector's facets including business and leisure.</p> <p>In accordance with the objective, the proposal will contribute mid-range hotel accommodation in the context of a growing office market for both business and leisure purposes.</p> <p>The Plan also identifies that '<i>planning controls need to be flexible to allow for the needs of the innovation economy</i>'. The site is within the Innovation Corridor and located in proximity to the Sydney Innovation and Technology Precinct. The Planning Proposal seeks to increase the amount of employment generating floor space on the site to support the growing innovation economy and the associated demand for temporary accommodation.</p>
Planning Priority E14	Protecting and improving the health and enjoyment of	The proposal provides an intermediate height relative to the scale of the surrounding future developments (i.e. 187 Thomas Street and 8 – 10 Lee Street). In this

Table 7 – Consistency with the Planning Priorities of the Eastern City District Plan

	Sydney Harbour and the District's waterways.	context, it will not obscure significant views of Sydney's waterways. Further, being positioned inland, the proposal will have no impact on views of the District's waterways.
Planning Priority E19	Reducing carbon emissions and managing energy, water and waste efficiently.	The proposal has the capacity to adopt best practice sustainability measures at the detailed design phase.

8.2.3 Camperdown-Ultimo Place Strategy

The *Camperdown-Ultimo Collaboration Area* is a Place Strategy (the Place Strategy) that was adopted by the Greater Sydney Commission in 2017. The Camperdown-Ultimo Collaboration Area stretches from Camperdown to Ultimo and encompasses the site as well as the wider Haymarket area and surrounding suburbs. Collaboration Areas are defined as areas of metropolitan significance that have the potential to emerge as nodes of activity that foster productivity and innovation.

The collaboration area supports three 'activity nodes' that occupy Haymarket, Camperdown and Eveleigh. The site forms part of the Haymarket Activity Node which is characterised by significant employment, educational, knowledge and skill contributors and will benefit from the *Central Station Urban Renewal Program*.

The Place Strategy identifies the aspiration for the area to emerge as Australia's innovation and technology capital. It provides an analysis of its opportunities, noting that due to the anticipated proliferation of tech start-ups, creative industries, and health education and research institutions within activity nodes such as Haymarket, that there will be a greater demand for ancillary and complementary uses including retail and visitor accommodation.

The Place Strategy nominates a range of priorities and actions to facilitate the achievement of its overarching vision. The table below demonstrates that the proposal is entirely consistent with the relevant actions.

Table 8 – Consistency with Camperdown-Ultimo Place Strategy

Action	Comment
Action 16	Encourage active street frontages and priorities pedestrians and cyclists.
	At least 70% of the street frontage is proposed to be activated by the retail uses facilitated by the LEP amendments. The proposed retail activation combined with the public domain upgrades will encourage the pedestrianisation of the area.
	The proposal seeks to provide vehicular access off Valentine Street which is envisaged by Council to serve as a shareway in the near future. The location of the proposed

Table 8 – Consistency with Camperdown-Ultimo Place Strategy

		driveway access point is consistent with the existing approval (DA/2017/353). As the proposal only seeks to provide 7 valet parking spaces, minimum traffic movements will result from the proposal. In turn, pedestrian movements will be prioritised.
Action 18	Foster vibrant places by activating night-time precincts, activating ground floor areas and developing and promoting meeting places and cultural assets.	The development facilitated by the Planning Proposal retains and adaptively reuses the heritage item.
Action 22	<p>Action 22 nominates the following:</p> <ul style="list-style-type: none"> reinforce and strengthen the local identity of Haymarket, Camperdown and Eveleigh activity nodes; Attracts investment and drives jobs growth; Improves the destination experience and grows the collaboration Area's global economic prosperity; and Supports convergence, attracts tech start-ups, encourages research and innovation clusters, and supports scaleups to reach commercial aspirations. 	The proposal will increase the amount of employment generating floor space on the site. It will provide retail and hotel floor space that will support the growing office market and the tourism sector. In this regard the proposal will support the economic competitiveness of the collaboration area.
Action 26	Retain and manage commercial and business activities by safeguarding business zoned land from conversion to residential development.	The Planning Proposal seeks to facilitate the redevelopment of the site for commercial and retail floorspace, which will increase its amount of employment generating floor space.

8.2.4 The Central to Eveleigh Urban Transformation Strategy

The *Central to Eveleigh Urban Transformation Strategy* (C2E Strategy) establishes a vision for the transformation and redevelopment of the Central to Eveleigh corridor. Although not located within the study area and associated precincts that form part of the corridor, the site has the capacity to contribute to meeting the objectives established by the C2E Strategy. The objectives are articulated under a range of 'key moves'.

Relevant key moves include:

- Key Move 6 – Create centres of activity around stations;
- Key Move 8 – Strengthen arts, culture and heritage; and
- Key Move 9 – Integrate new high-density mixed-use buildings with existing neighbourhoods and places.

The site is located adjacent to Central Precinct. The proposal aligns with the C2E Strategy in that it will foster increased activity around a transport node by concentrating needed visitor accommodation, retail activation and employment opportunities in proximity to Central Station. By adaptively reusing the site's heritage item, the proposal will preserve the locality's unique character, strengthening the area's heritage whilst it undergoes a process of transformation facilitated by the Draft CSPS.

8.2.5 NSW State Infrastructure Strategy 2018 – 2036

The *NSW State Infrastructure Strategy 2018 – 2036* (the Strategy) sets out the NSW Government's vision for infrastructure across the State over the next 20 years and aligns with the Greater Sydney Region Plan – *A Metropolis of Three Cities*.

The Strategy identifies that a key challenge for the Eastern Harbour City is to drive and accommodate growth and density alongside investment in infrastructure. It outlines a number of key infrastructure responses, including the need to invest in improvements in cultural infrastructure and tourism, and support the population with social infrastructure investment.

The Planning Proposal will deliver on the objectives of the Strategy in that it will:

- Support transport patronage associated with the existing and planned transport upgrades by increasing the supply of employment generating floor space in proximity to a major transport node;
- Support the visitor economy by providing accommodation floor space in proximity to transport infrastructure and the growing office market in Central Sydney South Precinct, thereby fostering links between business, tourism and accommodation; and
- Encourage public transport patronage by providing minimal on-site parking and end-of-trip facilities.

8.2.6 Future Transport Strategy 2056

The *Future Transport Strategy 2056* (the Strategy) prepared by Transport for NSW (TfNSW) was adopted in March 2018 and outlines a long-term plan for the three cities of Greater Sydney as well as Regional NSW. It establishes the overarching vision for transport to function as an enabler of economic and society activity in order to contribute to long term economic, social and environmental outcomes. To assist in achieving this vision, the Strategy provides a framework for guiding planning and investment in transport infrastructure. This framework is supported by the following objectives:

- Encouraging active travel (walking and cycling) and using public transport;
- Connecting people to jobs, goods and services in our cities and regions; and
- Supporting more environmentally sustainable travel.

The Planning Proposal will deliver on the above objectives by increasing employment opportunities on a site in walking distance of a major transport node and future metro stations. It consequently will foster active transport and will assist in connecting people to jobs, services and sustainable transport options.

Q3b – Does the proposal have site specific merit?

Having regard to the following:

- *The natural environment (including known significant environmental values, resources or hazards; and*
- *The existing uses, approved uses, and likely future uses of land in the vicinity of the proposal; and*
- *The services and infrastructure that are or will be available to meet the demands arising from the proposal and any proposed financial arrangements for infrastructure provision.*

With respect to the above, the Planning Proposal demonstrates site specific merit for the following reasons:

- It will increase the amount of employment generating floor space accommodated on the site and within a Tower Cluster Area, therefore supporting jobs growth in accordance with the Draft CSPA;
- It will benefit from recently delivered and planned transport upgrades which will ensure that the infrastructure in the locality has the capacity to support the density proposed for the site as well as the density to be realised in the broader surrounds following the implementation of the CSPA;
- It will deliver a tall slender tower that provides equivalent amenity impacts (i.e. solar access) to the adjoining property to the north, improved daylight conditions and the potential for equivalent wind conditions to the surrounding public domain;
- It will address the demand for ancillary retail and visitor accommodation uses necessary to support the growing workforce associated with the additional commercial floor space to be delivered under the revised planning controls prescribed by the Draft CSPA;
- It will support agglomeration benefits between the visitor economy and the expanding office market in south Central Sydney by delivering visitor accommodation within a Tower Cluster Area designated to support substantial increases in commercial floor space;
- It will facilitate improvements to the public domain and offers the potential for a through-site link that will enhance the permeability of the locality;
- It will reinforce Haymarket's local character by preserving and adaptively reusing the site's heritage item;
- It will provide a hotel development in a highly accessible location in proximity to a range of tourism and major event destinations located within the broader Harbour CBD;

- It provides a mix of uses that are permissible on the site within the B8 Metropolitan Centre Zone;
- It will introduce a contemporary tower that will facilitate the realisation the density envisaged for the Tower Cluster Area under the CSPA;
- It will result in an appropriately scaled tower that sits comfortably in the skyline that is earmarked to consist of towers reaching unprecedented heights;
- It will support the visitor economy by providing mid-range hotel accommodation that will address the demand for accommodation at more affordable price points in the context of there being an oversupply of 5-star hotels; and
- It will provide acceptable environmental impacts as evidenced by the accompanying subconsultant reports and the environmental assessment provided in **Section 9.0**.

In light of the merits of the proposal, it is considered that failing to redevelop the site in accordance with the vision set out in this Planning Proposal represents a missed opportunity. The likely outcomes of not redeveloping the site for the requested density are as follows:

- The site's existing building stock would remain in its current underutilised state. In consequence, a substantial portion of the floor space accommodated on the site would remain sterilised its current fire orders. Therefore, the retention of the existing built form would prevent any increase to the site's employment capacity which is contrary to the strategic intent of a Tower Cluster Area.
- Alternatively, the site could be redeveloped in accordance with the existing Development Application approval. However, the resultant outcome would be a development with a substantially reduced density comprising a tower reaching no more than 50m with a base FSR of 7.5:1 (excluding bonus FSR). This option forgoes the opportunity to deliver an increased amount of employment generating floorspace and a suitably scaled tower that sits comfortably in the context of the super towers earmarked for the locality.

Summary

For the reasons addressed above, this Planning Proposal is consistent with the Strategic Merit Test and Site Specific Merit Test established by *A Guide to Preparing Planning Proposals*.

Q4. Will the planning proposal give effect to a council's endorsed local strategic planning statement, or another endorsed local strategy or strategic plan?

The Planning Proposal is entirely consistent with Council's endorsed local strategies and plans. A detailed discussion regarding the proposal's compliance with the strategies and plans of relevance to the application is provided below.

8.2.7 Central Sydney Planning Strategy

The Draft CSPA is a 20-year growth strategy that delivers on Council's Sustainable Sydney 2030 program. As noted previously, it encompasses a suite of documentation that proposes amendments to the planning controls for the Central Sydney Planning Area.

The Draft CSPA situates the site within the Haymarket / Ultimo Tower Cluster Area (refer to **Figure 28**). The Tower Cluster Area is earmarked for employment growth and densification. Sites within Tower Cluster Areas are eligible for additional height and Strategic Floor Space to facilitate employment growth.

The Draft CSPA defines Strategic Floor Space as comprising floor space related to the following uses: *office premises, business premises, retail premises, hotel accommodation and community and cultural facilities*. The development facilitated by the Planning Proposal relates to retail and hotel accommodation, and therefore aligns with the requirements for Strategic Floor Space.

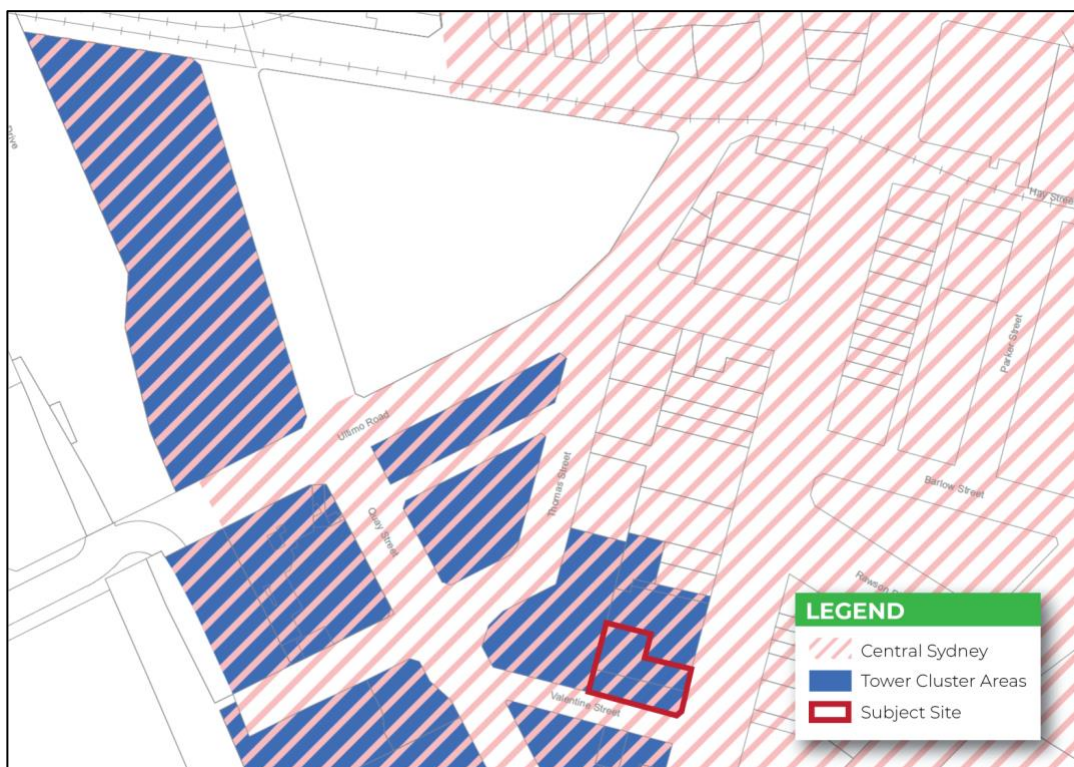

Figure 28 Site's Location within the Haymarket / Ultimo Tower Cluster Area
Source: CSPA Planning Proposal prepared by City of Sydney

The Draft CSPA provides a framework of 10 'key moves' which aim to drive the continued growth and economic success of Sydney and its expansion. The Planning Proposal is entirely consistent with the relevant key moves for the reasons set out in the table below.

Table 9 – Consistency with the Key Moves of the CSPA		
Key Move	Comment / Compliance	
1) <i>Prioritise employment growth and increase employment capacity.</i>	<p>The proposal seeks consent for employment generating uses comprising visitor accommodation and retail floor space. It will therefore assist in unlocking development capacity in a Tower Cluster Area.</p> <p>The proposal will increase the quantum of employment floor space achievable on the site to assist in meeting the target of an additional 2.9 million square metres of floor space. As outlined in the Economic Impact Assessment at Appendix 5, the proposal will contribute 127 jobs and \$8.5 million of indirect investment and therefore will enhance Central Sydney's productivity and employment growth.</p> <p>Whilst not subject to subclause 6.21 (7A), the development sought by this Planning Proposal demonstrates that the site is capable of accommodating a tower of the proposed density and contributing employment generating floor space without giving rise to unreasonable environmental impacts.</p> <p>Further discussion regarding environmental impacts is provided in Section 9.0.</p>	✓
2) <i>Ensure development responds to context.</i>	<p>The Strategy aims to promote flexible planning controls for tall buildings to ensure developments better respond to their context.</p> <p>This Planning Proposal seeks to amend the controls to provide a greater level of flexibility to facilitate the delivery of a tower that:</p> <ul style="list-style-type: none"> • Provides adequate setbacks and separation; • Preserves and is sympathetic to the site's heritage building and protects the area's local character; 	✓

Table 9 – Consistency with the Key Moves of the CSPS

	<ul style="list-style-type: none"> • Provides acceptable wind impacts; • Facilitates improved daylight to surrounding public places; and • Achieves a high standard of amenity and exhibits design excellence. <p>Further discussion regarding the appropriateness of the proposed tower's built form is provided in Section 9.1.</p>	
3) <i>Consolidate and simplify planning controls.</i>	<p>In an effort to consolidate and simplify planning controls, the Draft CSPS seeks to expand its geographical boundaries to southern Central Sydney to include Ultimo and Central Railway to maximise opportunities for growth.</p> <p>The site forms part of the Southern Central Sydney Precinct. The proposal facilitated by the Planning Proposal prepared under the guise of the Draft CSPS planning controls will contribute to the expansion of Central Sydney.</p>	✓
4) <i>Provide for employment growth in new tower clusters.</i>	<p>The site forms part of the Haymarket / Ultimo Tower Cluster Area. Being located in a Tower Cluster Area and close to other planned super towers as well as in proximity to transport infrastructure, the site is ideally suited to support a taller building with an intermediate scale relative to nearby planned developments.</p> <p>The development envisaged by the Planning Proposal will accommodate employment generating uses that deliver on the objectives of the Draft CSPS as well as other related Council policies which identify the need for mid-range hotel accommodation and active retail uses.</p>	✓
5) <i>Ensure infrastructure keeps pace with growth</i>	<p>The site receives ample access to existing and planned light and heavy public transport infrastructure.</p> <p>The Planning Proposal therefore capitalises on the existing and planned heavy infrastructure in the surrounds.</p>	✓

Table 9 – Consistency with the Key Moves of the CSPA

6) <i>Move towards a more sustainable city</i>	The proposal will adopt best practice sustainability measures as outlined in the ESD Report included at Appendix 6 .	✓
7) <i>Protect, enhance and expand Central Sydney's heritage and public places.</i>	The proposal seeks to retain and adaptively reuse the heritage listed building contained in the site. The proposal is therefore consistent with the objective as it will protect and enhance Central Sydney's historic heritage.	✓
8) <i>Move people more easily by prioritising street for walking and cycling and expanding the pedestrian open space network.</i>	The development facilitated by the Planning Proposal will prioritise pedestrian movements by contributing public domain upgrades; providing the opportunity for a through-site link; maximising active frontages; and providing upgrades at the ground plane.	✓
9) <i>Reaffirm commitment to design excellence</i>	The development as envisaged by the Indicative Concept Scheme along with the draft Site Specific DCP demonstrates that the proposed LEP amendments are capable of supporting a tower that exhibits design excellence at the detailed Development Application phase.	✓
10) <i>Monitor outcomes and respond to issues that arise to ensure the Strategy's ongoing success.</i>	Not Applicable	NA

8.2.8 Sustainable Sydney 2030

The City of Sydney's *Sustainable Sydney 2030 – Community Strategic Plan* (the Plan) establishes the vision and strategic plan for the City of Sydney for the next 25 years. It aims to guide Council to deliver outcomes in line with the community's expectations.

The Plan sets out 10 Strategic Directions to guide the implementation of the Plan. The proposal's consistency with the relevant Strategic Directions is addressed below.

Strategic Direction 1 – A globally and competitive city

The proposal will improve diversity in the economy by increasing the supply of mid-range hotel accommodation. It will provide high quality hotel accommodation that will contribute to enhancing Sydney's global status as a destination for investment, culture and business. By providing accommodation in proximity to Sydney's primary office market and tourism destinations, it will support links between domestic and international businesses as well as leisure visitors. It will also encourage job creation and contribute to the achievement of Council's target of 465,000 jobs by 2030.

Strategic Direction 2 – A leading environmental performer

This Planning Proposal will support the delivery of a development that adopts best practice sustainability measures as addressed in the ESD Report at **Appendix 6**.

Strategic Direction 3 – Integrated transport for a connected city

The site is located within walking distance of a range of range of transport options, including Central Station, the CBD and South East Light Rail network, bus services and the future Sydney Metro. By providing jobs and services it will foster the use of sustainable modes of transport.

Strategic Direction 4 – A city for walking and cycling

The Planning Proposal provides the opportunity for active retail frontages and a potential through-site link that will encourage the pedestrianisation of the area and will improve permeability.

Strategic Direction 5 – A lively and engaging city centre

The future development as facilitated by the Planning Proposal will provide fine-grain retail uses at ground level that will contribute to the revitalisation of the locality. The retail premises have the potential to support the night-time economy and contribute to an active streetscape both during the day and at night.

Strategic Direction 6 – Resilient and inclusive local communities

The development envisaged by the Planning Proposal will contribute to the creation of a unique place by adaptively reusing the site's heritage item and consequently preserving the locality's local character. It will provide employment opportunities, high quality mid-range tourist accommodation, and retail activation for both local residents and visitors.

Strategic Direction 7 – A cultural and creative city

The proposal provides the opportunity for the inclusion of public art at the detailed design phase. Any future public art will ensure creativity is a visible feature of the public domain and will enhance the distinctive identity of the Haymarket locality.

Strategic Direction 9 – Sustainable development, renewal and design

This Planning proposal will facilitate the delivery of a future development that adopts a high standard of ESD practices and meets a range of ESD targets (refer to **Appendix 6**). By virtue of being located in walking distance of public transport, the proposal will encourage the use of sustainable modes of transport and reduce the reliance on private motor vehicles.

Strategic Direction 10 – Implementation through effective governance and partnerships

The Planning Proposal will support the implementation of *Sustainable Sydney 2030*. Should the proposal progress to public exhibition, the community will be provided with an opportunity to comment on the proposal.

8.2.9 City Plan 2035 – Local Strategic Planning Statement

The *City Plan 2035 – Local Strategic Planning Statement* (LSPS) provides a 20-year land use planning vision for the Sydney LGA. It connects the Greater Sydney Region Plan: A Metropolis of Three Cities, the Eastern City District Plan, Sustainable Sydney

2030: Community Strategic Plan with Council's existing and proposed planning controls.

Strategic Planning Opportunity

The objectives established by the LSPS align with the strategic aspirations of the subject Planning Proposal, which aims to redevelop the site for a 3.5-star hotel with ancillary retail uses that respond to the growth of Central Sydney.

The LSPS recognises that Sydney's visitor economy is instrumental to fostering links between international and national businesses, with more than one third of Sydney's visitors travel to Sydney for business reasons. For this reason, the LSPS identifies that supporting the viability of the visitor economy is a key priority for improving the competitiveness of the local economy.

The LSPS notes that a diversity of hotel accommodation types that respond to different market segments need to be delivered in suitable locations. More diverse hotel options have the potential to connect the growing international and transient workforce with the expanding office market in the south Central Sydney and to foster agglomeration benefits. However, the LSPS identifies a number of preventative barriers to the delivery of varying grades of hotel accommodation. In particular, high-land values and the financial gains associated with residential accommodation disincentivise the redevelopment of sites for mid-range and budget accommodation.

In light of this, the LSPS establishes that the demand for hotels is projected to grow by 4.7% annually to 2020, with demand projected to be stronger for mid-range accommodation. To ensure Sydney remains a drawcard for visitors, the LSPS identifies that future hotel developments should aim to deliver place-led and people focused outcomes.

The LSPS situates the site in the Central Sydney South Precinct, which is designated to be a strategically important employment area due to the planning infrastructure investments at Central and the emerging Sydney Technology and Innovation Precinct. The area is anticipated to experience significant transformation due to the expected shift towards high-order employment uses. This shift will precipitate a demand for ancillary and complementary uses, including retail and hotel uses.

In light of the above, the Planning Proposal aligns with the strategic planning opportunities and priorities identified by the LSPS. Specifically, it:

- Will provide mid-range accommodation floor space in the form of a 3.5-star hotel that will address the projected demand for more affordable tourist and visitor accommodation options;
- Will address the demand for temporary hotel accommodation emanating from the growing workforce in Central Sydney South Precinct which will experience higher levels of visitation as a consequence of the shift towards high-order employment uses and the emergence of the Sydney Technology and Innovation Precinct;
- Adopts a place-based approach to redeveloping the site by adaptively reusing its heritage item to deliver a place-led outcome that is sympathetic to Haymarket's local identity and character;

- Seeks to redevelop a site capable of accommodating a viable floor plate with minimal environmental impacts; and
- Retains and intensifies the site's use for employment generating purposes in lieu of facilitating its conversion to a residential use.

Consistency with Relevant LSPS Priorities

The development facilitated by the Planning Proposal will give effect to a range of priorities nominated by the LSPS. The proposal's consistency with the relevant priorities is addressed in the table below.

Table 10 – Consistency with the Relevant LSPS Priorities		
Priority		Consistency
Infrastructure		
I1	Movement for walkable neighbourhoods and a connected city.	The proposal provides the opportunity for public domain upgrades at the ground plane and a potential through-site link. It will therefore improve connectivity to the surrounds and contribute to a more walkable neighbourhood.
I2	Align development and growth with supporting infrastructure.	The density proposed by the site capitalises on existing and planned transport infrastructure, including the recently delivered light rail and future Sydney Metro. Both projects will provide significant additional public transport capacity.
Liveability		
L1	A creative and socially connected city	<p>The proposal will improve access to services and uses to meet people's changing needs. Specifically, it will provide mid-range hotel accommodation floor space that will address the growing demand for short-term accommodation in south Sydney's expanding office market.</p> <p>The proposal will foster a healthy, creative and culturally rich community by retaining and revitalising the site's heritage building to allow it to positively contribute to the unique character of the locality.</p>
L5	Creating Great Places	<p>The proposal will provide high quality retail uses that will contribute to the activation of the streetscape.</p> <p>The retained heritage building will contribute to the local character of the area. The proposed uses comprising hotel</p>

Table 10 – Consistency with the Relevant LSPS Priorities

		<p>and retail/commercial floor space will cater to the daily needs of the local community and its growing workforce.</p> <p>The development facilitated by the Planning Proposal provides the opportunity for a through-site link which will foster walkability.</p>
Productivity		
P7	Growing a stronger, more competitive Central Sydney	The Planning Proposal will support the productivity of Central Sydney by enhancing the site's capacity to support employment generating floor space.
P8	Developing innovative and diverse business clusters in City Fringe	The LSPS identifies that the City Fringe is a drawcard for investment and is known for its knowledge intensive clusters and character. The Planning Proposal will increase the diversity of uses within the City Fringe by providing ancillary hotel accommodation and retail floor space that will complement and support growth of its knowledge-intensive clusters and the tech sector in the nearby Western Gateway Precinct.
Sustainability		
S11	Creating better buildings and places to reduce emissions and water and use water efficiently	The development facilitated by the Planning Proposal will adopt best practice sustainability measures and will be designed to meet ambitious sustainability targets.

Principles for Growth

The LSPS sets out a series of 'principles for growth' which represent a local merits test to guide Council in their consideration of Planning Proposals. The 'principles for growth' supplement the Strategic Merit Test and Site Specific Merit Test established by the DPIE's *Guide to Preparing Planning Proposals*. An assessment against the principles is provided in the table below.

Table 11 – LSPS's Strategic and Site Specific Principles for Growth

Principle	Comment / Compliance
Strategic Principles for Growth	
<i>Proposals must be consistent with the Greater Sydney Region Plan and Eastern City District Plan</i>	The proposal is consistent the Greater Sydney Region Plan and the District Plan for the reasons addressed above in Section 8.2.1 . ✓
<i>Proposal's for sites in the Harbour CBD, Innovation Corridor (including Camperdown-Ultimo Health and Education Precinct) must be consistent with the objectives for these areas in the Eastern City District Plan.</i>	The proposal is consistent with the District Plan for the reasons set out above in Section 8.2.2 and Section 8.2.3 . ✓
<i>Proposals must be consistent with the directions, objectives and actions of Sustainable Sydney 2030 and Sustainable Sydney 2050 in the future.</i>	The proposal is consistent with Sustainable Sydney 2030 for the reasons addressed in Section 8.2.8 . ✓
<i>Proposals must be consistent with the relevant livability, productivity, infrastructure and sustainability priorities, objectives and actions in this LSPS.</i>	The proposal is entirely consistent with the objectives and actions in the LSPS for the reasons set out in Section 8.2.9 . ✓
<i>Proposals must be consistent with the relevant priorities, objectives and actions of the Local Housing Strategy.</i>	The proposal relates to a site in a Tower Cluster Area and does not seek consent for residential accommodation. Accordingly, the provisions do not apply. ✓
<i>Proposals must support the strategic objectives in the City's adopted strategies and action plans.</i>	As demonstrated by the assessment provided in Section 8.2.7 to Section 8.2.12 the proposal is entirely consistent with Council's strategies and action. ✓
<i>Proposal's must not compromise non-residential development need to meet employment targets for strategic centres.</i>	The proposal relates to an employment generating use. It has the potential to facilitate the creation of 127 jobs during the operational phase and will therefore contribute to meeting Council's employment targets. ✓
<i>Proposals which seek to respond to a significant investment in infrastructure must be considered in a wider strategic context with other sites.</i>	The site receives ample access to existing and planned public transport. Specifically, the proposal is located in walking proximity of Central Station and a number of light rail stations and planned metro stations. In consequence, there is sufficient transport ✓

Table 11 – LSPS's Strategic and Site Specific Principles for Growth

	infrastructure in the locality to support the density sought by the Planning Proposal.	
<i>Proposals must give consideration to strategically valuable land uses that are under-provided by the market, such as but not limited to hotels, cultural space (including performance and production space), and having regard to the appropriateness of the use for the context.</i>	The proposal seeks consent for a 3.5-star hotel use. As addressed above, the proposal responds to the growing demand for mid-range accommodation that is appropriate for the context given the anticipated growth of the local workforce following the implementation of the Draft CSPA controls.	✓
The Site Specific Principles for Growth		
<i>Proposals must locate development within reasonable walking distance of public transport that has capacity and is frequent and reliable.</i>	The proposal is located within walking distance of a range of transport options. In particular, it is located 250m from Central Station, 270m from Capitol Square Light Rail Station, 140m of Haymarket Light Rail Station. The site will also benefit from the planned Sydney Metro and the upgrades to Central Station.	✓
<i>Proposals must meet high sustainability standards and mitigate negative externalities.</i>	The proposal is capable of incorporating best practice sustainability measures at the design competition and detailed Development Application phases.	✓
<i>Proposals must include an amount and type of non-residential floor space appropriate to the site's strategic location and proximity to or location with a centre or activity street.</i>	The site is located within the Haymarket/Ultimo Tower Cluster Area. It seeks to provide employment generating floor space consisting of retail and hotel accommodation. The proposed uses are ancillary and complementary to the growing office market in south Central Sydney and are therefore appropriate.	✓
<i>Proposals must create public benefit.</i>	The proposal will provide public domain upgrades that will improve the visual amenity of the area and its permeability. Additional public benefits will be provided under a future Voluntary Planning Agreement. A Public Benefit Offer is included under Separate Cover. Further discussion is provided in Section 9.15 and Section 9.16 .	✓
<i>Proposals must be supported by an infrastructure assessment and demonstrate any demand for infrastructure it generates can be</i>	The site is located adjacent to Sydney's largest public transport interchange with this being Central Station. It is also located in proximity to a number of light rail stations	✓

Table 11 – LSPS's Strategic and Site Specific Principles for Growth

<p><i>satisfied, assuming existing development capacity in the area will be delivered.</i></p>	<p>and bus services, and will benefit from the planned Sydney Metro network. Accordingly, the existing and future transport infrastructure in the immediate vicinity of the site has ample capacity to support the demand for infrastructure associated with the proposal.</p>	
<p><i>Proposals must make a positive contribution to the built environment and result in an overall better urban design outcome than existing planning controls.</i></p>	<p>The indicative Preferred Scheme demonstrates that a building that exhibits design excellence and provides floor plates appropriately sized for the proposed use is capable of being delivered within the parameters of the LEP amendments.</p> <p>Relative to a complying scheme permitted to reach no more than 50m, the proposal will generate a superior design outcome by responding to developments in the surrounds. Specifically, it will provide a better transition in height from the surrounding built form which being located in a Tower Cluster Area is permitted to reach heights in excess of RL 200. In particular, relative to the existing approval, the proposal will provide a more gradual transition in height from the tower at 187 Thomas Street (if approved) which proposes a DCP Envelope reaching 216.4m.</p> <p>As such, relative to a complying scheme, the proposal will provide a slender tower that complements and better integrates with planned and potential permissible developments in the surrounds.</p> <p>Further discussion is provided in Section 9.1.</p>	<p>✓</p>
<p><i>Proposals must result in high amenity for occupants.</i></p>	<p>The LEP amendments will facilitate the provision of floor plates suitable for accommodating a 3.5-star hotel. As demonstrated by the indicative Preferred Scheme the rooms are adequately sized for the proposed grade of hotel and are generally oriented towards the south to maximise access to view corridors and are identified by supporting subconsultant findings as capable of receiving adequate solar. Occupants will also have access to amenity hotel rooms.</p>	<p>✓</p>

Table 11 – LSPS's Strategic and Site Specific Principles for Growth

<i>Proposals must optimise the provision and improvement of public space and public connections.</i>	The proposal has the opportunity to deliver public domain upgrades, a through-site link and retail activation at the ground plane.	✓
--	--	---

8.2.10 Visitor Accommodation Action Plan

The *Visitor Accommodation Action Plan (Hotels and Serviced Apartments)* (the Plan) was released in 2015 and builds upon *Sustainable Sydney 2030*. It identifies the challenges impacting the hotel accommodation sector and nominates a range of actions to increase investment in the sector.

The Plan notes that a key challenge affecting the sector is the oversupply of 5-star hotels, which encourages lower occupancy rates and drives down hotel rates. This is exacerbated by the development pipeline for visitor accommodation which predominantly consists of 4 and 5-star hotels.

In the context of there being an oversupply of 5-star accommodation, there is a growing demand for mid-range accommodation, particularly in the 3.5-star segment. However, the pressure for hotel and commercial uses to be converted to residential represents an impediment to the delivery of mid-range hotels that provide more affordable accommodation options.

The Plan identifies that there is a correlation between the demand for hotel accommodation and office markets due to the flux of corporate travelers that require temporary accommodation. Given this, it can reasonably be anticipated that the emerging Sydney Innovation and Technology Precinct along with the growing office market associated with the Central/Haymarket Tower Cluster Area will increase the demand for accommodation for corporate travelers.

In addition, the Plan recognises that there is a growing demand for a greater diversity of hotel types, with leisure visitors demonstrating a strong preference for standard grade hotels. It anticipates that future demand will exhibit a stronger preference for mid-range accommodation at more affordable rates.

The Plan nominates a range of actions to assist in meeting future demand and to encourage greater investment in the development of hotel accommodation. Of relevance to this Planning Proposal are the following actions:

- d) *The City will consider visitor accommodation and encourage proponents to investigate visitor accommodation, when proposing planning controls for strategic or major development sites.*
- e) *Investigate encouraging 3-star hotels in the western, southern and core precincts of Central Sydney by reducing development costs including development contributions and heritage floor space.*

The proposal is entirely consistent with the Plan and its relevant actions. Specifically, it relates to a site that is strategically significant due to its positioning within a Tower Cluster Area, the Innovation Corridor and proximity to the emerging Sydney

Innovation and Technology Precinct. Consistent with the Plan, it will increase the supply of mid-range hotel accommodation in the Southern Central Sydney Precinct.

8.2.11 Retail Action Plan

The City of Sydney's *Retail Action Plan* (the Action Plan) builds upon Sustainable Sydney 2030 and provides a more detailed framework for the retail sector which is identified as one of Sydney's priority sectors. The Action Plan prescribes a number of actions that seek to foster the maintenance and growth of retailers, particularly those with an on-street presence.

The Action Plan is focused on five key areas, these being:

- *Create great experiences;*
- *Building capacity and resilience;*
- *Remove barriers; and*
- *Engage with the sector.*

These focus areas are supported by a number of major projects. Relevant projects include:

- The activation of laneways and fine-grained retail spaces to encourage their take-up by diverse and bespoke businesses;
- The development and implementation of a legible way-finding systems for Central Sydney; and
- Advocating for improvements to transport and access in the City.

The development facilitated by the Planning Proposal is entirely consistent with the aspirations of the Action Plan. By providing fine-grained retail uses at street level it will attract diverse and bespoke business to the locality. These future retail businesses will benefit from the site's proximity to public transport and the growth of the office sector in the South Central Sydney Precinct. It will also facilitate public domain upgrades at the ground plane. These improvements will enhance pedestrian movements and wayfinding, which will improve the legibility of the proposed retail uses.

8.2.12 Tourism Action Plan

The *Tourism Action Plan* was adopted in December 2013 and establishes a range of actions to support the viability of Sydney's tourism sector. It identifies that hotels are a critical part of the built infrastructure that service the tourism sector.

The Tourism Action Plan focuses on three core areas, including:

- *Destination Development* – Encouraging the development of product and infrastructure;
- *Destination Management* – Enhancing the quality of the visitor experience; and
- *Destination Marketing* – Strengthening partnerships to maximise visitation potential.

With respect to these three core areas, the *Tourism Action Plan* prescribes a range of key actions. To encourage the delivery of destination development, it nominates the following actions:

- Investigate through the Central Sydney Planning Review how planning controls can facilitate greater hotel development in Central Sydney;
- Work with partners to encourage appropriate conservation and adaptive re-use of heritage buildings within the city for visitor accommodation and other tourism related uses where it is consistent with the heritage significance of the building;
- Encourage the rejuvenation of obsolescent buildings in key destination precincts; and
- Continue to activate underutilised laneways and support fine grained retail spaces through public domain improvements.

The Planning Proposal will deliver on the actions set out in the *Tourism Action Plan*. Specifically, it will capitalise on the opportunity to deliver a hotel development under the future CSPS controls in a Tower Cluster Area that incentivises hotel accommodation floor space and is earmarked for significant employment growth.

Consistent with the Plan's actions, it will enhance the quality of the visitor experience by adaptively reusing and rejuvenating a heritage building for visitor accommodation alongside the provision of fine-grained retail spaces and public domain improvements.

8.2.13 A Change in Context and Circumstances

The Planning Proposal has been prepared in direct response to the changing economic landscape facilitate by investment in infrastructure and anticipated changes to the planning controls for Central Sydney.

Central Sydney is the focal point of Australia's economic activity. It is due to benefit from unprecedented levels of investment in public transport infrastructure, including the Sydney Metro, the upgrades to Central Station and has also benefited from the recently delivered CBD and South East Light Rail. It is projected that these transport upgrades combined with all other existing modes of travel will provide capacity for approximately 470,000 jobs by 2051.

These projects lead by the NSW Government represent the largest investment in transport infrastructure since the 1980s and will precipitate a demand for employment floor space and the expansion of Central Sydney geographic boundaries.

Concomitant with the investment in heavy and metro infrastructure, the Draft CSPS provides a framework for amending the existing planning controls to unlock additional 2.9 million square metres of additional floor space capacity for economic and employment growth. A large portion of this floor space is to be realised in designated Tower Cluster Areas, including the Haymarket / Ultimo Tower Cluster Area to which the site is located and will facilitate the expansion of Central Sydney's office market footprint further southward.

The Planning Proposal will increase the supply of high quality retail and tourism accommodation floor space that responds to market needs. This floor space will cater to the visitor economy as well as corporate travelers, and in turn will introduce ancillary and complementary uses that will support the expansion of Central Sydney and the growth of the Haymarket / Ultimo Tower Cluster Area.

8.2.14 Economic Justification and Prevailing Market Conditions

A Supply and Demand Analysis has been prepared by SMA Tourism to address the current and projected future demand for visitor accommodation in Central Sydney (refer to **Appendix 7**). The analysis has been prepared in recognition that the data prepared by JLL used to inform Council's *Visitor Accommodation Action Plan* was commissioned in 2014 and is therefore not a reflection of current market trends. The analysis also addresses the implications of COVT – 19, noting that the pandemic will result in short term impacts only.

Demand Analysis

The Demand Analysis indicates that there is a strong demand for mid-range accommodation. Whilst occupancy rates for mid-range accommodation have been susceptible to fluctuations, they reached a peak of 90% during the period from 2012 to 2019 and room rates gradually trended upwards from \$130 to \$152. More recently, between 2018 and 2019, occupancy rates for mid-range accommodation averaged 84.3%. By contrast, the occupancy rates across all grades of accommodation averaged only 82.5%

Supply Analysis

The Supply Analysis prepared by SMA Tourism addresses the existing and future pipeline for hotel developments across Central Sydney. In terms of the existing hotel stock, 84% comprises 4 or 5-star hotels. By comparison, only 16% consist of 3.5-star or less. Only two hotels in the vicinity of the site relate to 3.5-star accommodation with these being the APX World Square Sydney and 1831 Boutique Hotel. These hotels are located 530 and 850m from the site respectively and are therefore not in the immediate surrounds.

With respect to future supply, there are currently six hotel developments under construction with another two planned. By 2023, these developments will deliver an additional 2,511 hotel rooms. All are approved to deliver 4.5-star, 5-star and 6-star accommodation and therefore do not address the demand for more affordable mid-range accommodation comprising 3.5 stars or less. Further, the majority of these developments will be delivered in the CBD and will not address the expected demand for hotel accommodation in southern Central Sydney resulting from its growing office market.

Short Term Market Fluctuations

SMA Tourism note that the COVID-19 pandemic has impacted the demand for visitor accommodation. Nonetheless, these impacts are anticipated to be short term and will reverse following the removal of travel restrictions. Due to Australia's isolation from Countries that have been more adversely impacted by the pandemic, it is likely to benefit from increased levels of inbound tourism during the post recovery phase.

Relative to competing tourism sectors interstate, Sydney's tourism sector benefits from higher than average levels of non-holiday travelers such as corporate visitors. Further, Sydney's tourism sector is less reliant on travelers over 55-years of age who have been more adversely impacted by the pandemic. For these reasons, Sydney's tourism sector is expected to experience greater growth in the post-pandemic

phase. As a corollary, there will be a resurgence in the demand for visitor accommodation.

Q5. Is the planning proposal consistent with applicable State Environmental Planning Policies?

The proposal would address and/or be consistent with all relevant Environmental Planning Policies (SEPPs). The following outlines the intent of the relevant SEPPs and consistency of the Planning Proposal.

Table 12 – Consistency with State Environmental Planning Policies		
SEPP	Consistent	Comments
SEPP No. 52 – Farm Dams and Other Works in Land and Water Management Plan Areas	N/A	Not relevant to proposed LEP amendment.
SEPP No. 55 - Remediation of Land	✓	<i>State Environmental Planning Policy No. 55 – Remediation of Land</i> aims to promote the remediation of contaminated land. The Remediation Action Plan included at Appendix 8 confirms that the proposal can be made suitable for the intended use.
SEPP No. 64 – Advertising and Signage	NA	Not relevant to proposed LEP amendment. May apply to a future development at the detailed design phase.
SEPP No. 65 – Design Quality of Residential Flat Development	✓	<i>State Environmental Planning Policy No. 65 – Design Quality of Residential Apartment Development</i> and the associated Apartment Design Guide (ADG) establishes the design standards for apartment development. The development facilitated by the LEP amendment provides visitor accommodation and therefore the provision of the SEPP do not strictly apply. However, as the proposal interfaces with a residential flat building to the north, consideration has been given to key provisions where relevant to demonstrate the acceptability of the proposal (refer to Section 9.1.3.1).
SEPP (Affordable Rental Housing) 2009	NA	Not relevant to proposed LEP amendment.
SEPP (Building Sustainability Index: BASIX) 2004	NA	Residential development is not proposed and accordingly the SEPP does not apply.

Table 12 – Consistency with State Environmental Planning Policies

SEPP (Exempt and Complying Development Codes) 2008	NA	Not relevant to the proposed LEP amendment. May be relevant to a future DA.
SEPP (Infrastructure) 2007	✓	<p><i>State Environmental Planning Policy (Infrastructure) 2007</i> aims to facilitate the effective delivery of infrastructure.</p> <p>The LEP amendments facilitate a type of commercial development with a GFA of 12,318m². Accordingly, any future DA application will require referral to Roads and maritime Services.</p> <p>It is noted that the site is not located in the immediate vicinity of a rail or metro corridor.</p>
SREP (Sydney Harbour Catchment) 2005	✓	<p>The site falls within the Sydney Harbour Catchment. The proposal is consistent with the relevant Planning Principles in that it will have no impact on the health of the catchment or give rise to any environmental impacts.</p> <p>The proposal is located a significant distance from Sydney Harbour's foreshore. It is also located within a Tower Cluster Area earmarked to accommodate large scale towers. Future proposals in the area are designated to reach unprecedented heights of approximately RL 200. The proposed tower is relatively smaller in scale. In this context, it will have no impact on the scenic quality of the catchment for the following reasons:</p> <ul style="list-style-type: none"> • In the context of the larger scale developments in the surrounds, it will not be visible from the Sydney Harbour waterway and therefore will have no impact on important vantage points. • It will not impact publicly accessible vantage points for viewing Sydney Harbour; and • It will not impact the scenic quality of the foreshore.

Q6. Is the planning proposal consistent with applicable Ministerial Directions (s.9.1 directions)?

Table 13 – Section 9.1 Ministerial Directions			
Clause	Direction	Consistent	Comments
1 Employment and Resources			
1.1	Business and Industrial Zones	✓	The proposal is consistent with the direction as it will encourage employment growth by increasing the supply of employment generating floor space in a designated Tower Cluster Area as defined by Council's strategic planning framework.
1.2	Rural Zones	N/A	
1.3	Mining, Petroleum Production and Extractive Industries	N/A	
1.4	Oyster Aquaculture	N/A	
1.5	Rural Lands	N/A	
2 Environment and Heritage			
2.1	Environmental Protection Zones	N/A	The proposal does not relate to environmentally sensitive land.
2.2	Coastal Protection	N/A	
2.3	Heritage Conservation	✓	The Planning Proposal is consistent with the direction as it will facilitate the conservation of the site's heritage significant fabric. Further discussion is provided in Section 9.8.
2.4	Recreation Vehicle Areas	N/A	
2.5	Application of E2 and E3 Zones and Environmental Overlays in Far North Coast LEPs	N/A	
2.6	Remediation of Contaminated Land	N/A	The site is not a designated investigation area within the meaning prescribed by the

Table 13 – Section 9.1 Ministerial Directions

			<i>Contaminated Management Act 1997.</i>
3 Housing, Infrastructure and Urban Development			
3.1	Residential Zones	N/A	
3.2	Caravan Parks and Manufactured Home Estates	N/A	
3.3	Home Occupations	N/A	
3.4	Integrated Land Use and Transport	✓	The Planning Proposal is consistent with the relevant objectives in that it will increase jobs in walking distance to public transport. It provides limited opportunities for on-site parking and therefore will foster the use of public transport and reduce the reliance on private vehicles.
3.5	Development Near Regulated Airports and Defence Airfields	N/A	The Planning Proposal facilitates a development with a height of 105.87m which will not penetrate the Obstacle Limitation Surface (OLS), which is 156m in Central Sydney.
3.6	Shooting Ranges	N/A	
3.7	Reduction in non-hosted short term rental accommodation period	N/A	
4 Hazard and Risk			
4.1	Acid Sulfate Soils	✓	The SLEP 2012 classifies the site as containing class 5 Acid Sulfate Soils. The Preliminary Geotechnical Investigation Report at Appendix 17 confirms that the future works associate with the proposal will not trigger the need for an acid sulfate assessment.
4.2	Mine subsidence and Unstable Land	N/A	

Table 13 – Section 9.1 Ministerial Directions

4.3	Flood Prone Land	✓	The SLEP 2012 and the associated Darling Harbour Catchment Flood Study does not identify the site as being flood prone. Further discussion is provided in the Flood Certification Statement at Appendix 9 .
4.4	Planning for Bushfire Protection	N/A	
5 Regional Planning			
5.1	Implementation of Regional Strategies	N/A	The Planning Proposal is consistent with the Regional strategic planning framework. Further discussion is provided in Section 8.2 .
5.2	Sydney Drinking Water Catchments	N/A	
5.3	Farmland of State and Regional Significance on the NSW Far North Coast	N/A	
5.4	Commercial and Retail development along the Pacific Highway, North Coast	N/A	
5.5	Development in the vicinity of Ellalong, Paxton and Millfield (Cessnock LGA) (Revoked 18 June 2010)	N/A	
5.6	Sydney to Canberra Corridor (Revoked 10 July 2008. See Amended Directions 5.1)	N/A	
5.7	Central Coast (Revoked 10 July 2008. See amended Directions 5.1)	N/A	
5.8	Second Sydney Airport: Badgerys Creek	N/A	
5.9	North West Rail Link Corridor Strategy	N/A	

Table 13 – Section 9.1 Ministerial Directions

5.10	Implementation of Regional Plans	N/A	The Planning Proposal is consistent with the Regional and District Plan. Further discussion is provided in Section 8.2.
5.11	Development of Aboriginal Council Land	N/A	
6 Local Plan Making			
6.1	Approval and Referral Requirements	N/A	No new concurrence provisions are required.
6.2	Reserving Land for Public Purposes	N/A	The Planning Proposal will not create, alter or reduce existing zonings or reservations of land for public purposes.
6.3	Site Specific Provisions	✓	The Planning Proposal will not result in any unnecessarily restrictive site specific planning controls. The proposed site specific provision is intended to facilitate the orderly development of the site.
7 Metropolitan Planning			
7.1	Implementation of A Plan for Growing Sydney	✓	The Planning Proposal is entirely consistent with the provisions of the Greater Sydney Region Plan and therefore will facilitate its implementation. Further discussion is provided in Section 8.2.1.
7.2	Implementation of Greater Macarthur Land Release Investigation	N/A	
7.3	Parramatta Road Corridor Urban Transformation Strategy	N/A	
7.4	Implementation of North West Priority Growth Area Land Use and Infrastructure Implementation Plan	N/A	
7.5	Implementation of Greater Parramatta Priority Growth	N/A	

Table 13 – Section 9.1 Ministerial Directions

	Area Interim Land Use and Infrastructure Implementation Plan		
7.6	Implementation of Wilton Priority Growth Area Interim Land Use and Infrastructure Implementation Plan	N/A	
7.7	Implementation of Glenfield to Macarthur Urban Renewal Corridor	N/A	
7.8	Implementation of Western Sydney Aerotropolis Interim Land Use and Infrastructure Implementation Plan.	N/A	
7.9	Implementation of Bayside West Precincts 2036 Plan	N/A	
7.10	Implementation of Planning Principles for the Cooks Cove Precinct	N/A	

8.3 Section C - Environmental, Social and Economic Impact

Q7. Is there any likelihood that critical habitat or threatened species, populations or ecological communities, or their habitats, will be adversely affected as a result of the proposal?

There are no critical habitat or threatened species, populations or ecological communities, or their habitats on or around the site that will be affected by this Planning Proposal.

Q8. Are there any other likely environmental effects as a result of the planning proposal and how are they proposed to be managed?

The Planning Proposal seeks amendments to the maximum building height and floor space ratio to facilitate the orderly redevelopment of the site.

As evidenced by the discussion in **Section 9.0** and supporting subconsultant reports, the proposed amendments to the LEP development standards will not result in adverse environmental impacts. Potential impacts, such as those during the construction phase, are capable of being managed using appropriate mitigation measures.

Q9. Has the planning proposal adequately addressed any social and economic effects?

The planning proposal will create a number of positive social and economic outcomes which are discussed in detail in **Section 9.16**.

In summary, the proposal will:

- Provide 12,318m² of retail and commercial floor space which will facilitate job creation and contribute to and strengthen Sydney's role as a globally competitive City;
- Contribute to the creation of 129 jobs in the operational phase;
- Contribute to 787 indirect and direct 'construction jobs years' when accounting for multiplier effects;
- Contribute 8.5 million worth of indirect investment in the economy associated with expenditure from hotel guests;
- Increase accessibility and activation of a through-site link; and
- Improve safety and amenity of the surrounding public domain.

8.4 Section D - State and Commonwealth Interests

Q10. Is there adequate public infrastructure for the planning proposal?

As the site is located within Central Sydney, the existing infrastructure is capable of being augmented to support a future development facilitated by the Planning Proposal.

The site is located within walking distance of Central Station Transport Interchange, a number of light rail stations and the future Sydney Metro network. It therefore receives ample access to public transport. By increasing the supply of jobs on the site, the proposal will encourage public transport patronage and use of the surrounding transport network.

The planned upgrades to Central Station along with the delivery of Sydney Metro network and the recent construction of the light rail represent an unprecedented investment in public transport which will support the expansion of Central Sydney. In light of this, the Planning Proposal represents one of the first applications for the Haymarket / Ultimo Tower Cluster Area under the Draft CSPA controls. With the existing and planned transport upgrades, the infrastructure in the locality has the capacity to support the proposal and envisaged density.

Q11. What are the views of state and Commonwealth public authorities consulted in accordance with the Gateway determination?

The views of State and Commonwealth public authorities will be known once consultation has occurred at the Gateway Determination phase.

Should a Development Application be prepared following the implementation of the LEP amendments, the application would require referral to Roads and Maritime Services as the likely proposed commercial GFA would exceed the threshold prescribed under Clause 104 of the Infrastructure SEPP (2007) associated with traffic generating development.

9 Environmental Assessment

This section provides a further assessment of the Planning Proposal's site specific merits and addresses the key planning issues associated with the proposal.

To demonstrate the appropriateness of the proposed LEP amendments, Grimshaw have prepared an indicative Preferred Scheme. The Preferred Scheme demonstrates how a future development may be facilitated by the proposal within the parameters of the proposed LEP amendments.

For the reasons set out below, the Preferred Scheme confirms that the proposed LEP amendments are capable of supporting a development that achieves an improved built form outcome relative to a complying scheme and results in acceptable environmental impacts.

9.1 Built form and Urban Design

9.1.1 Podium

The podium facilitated by the Planning Proposal complies with the requirements of the Draft DCP. Under the Draft DCP the site forms part of the Haymarket / Chinatown Special Character Area. The Draft DCP nominates a maximum street wall height of 20m and a minimum street wall of 14m to align with the heritage building contained within the site.

To comply with the Draft DCP, the podium adopts the minimum street wall height to align with the site's heritage building and reflect its proportions (refer to **Figures 29 – 30**).

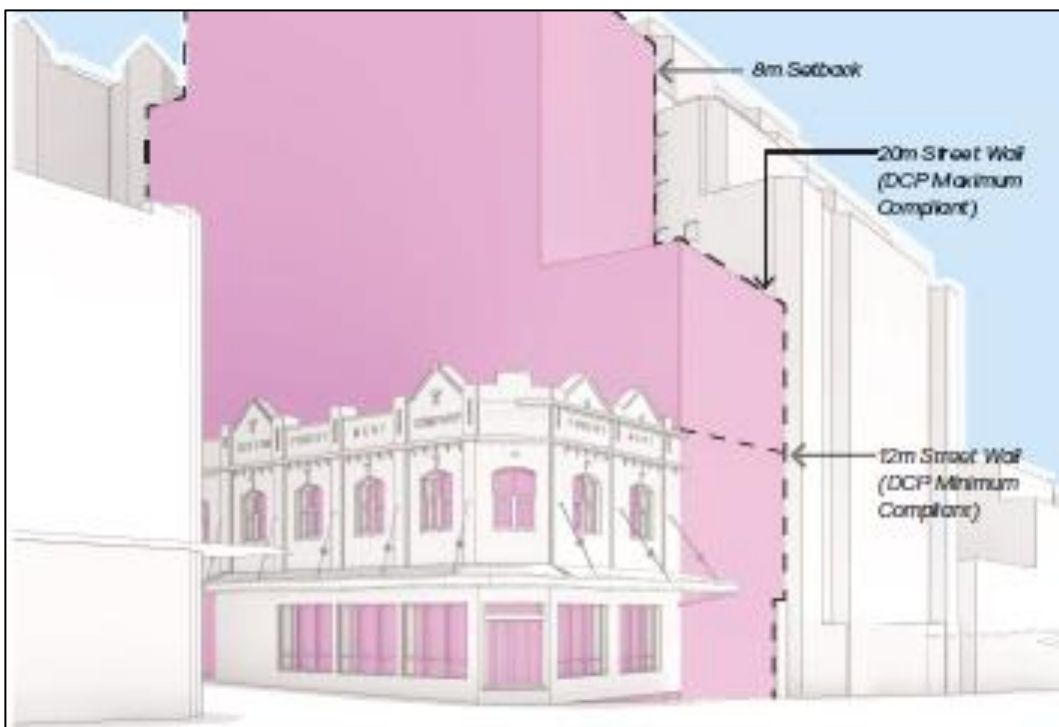

Figure 29 Compliant Eastern Setback and Street Wall of 20m
Source: Grimshaw

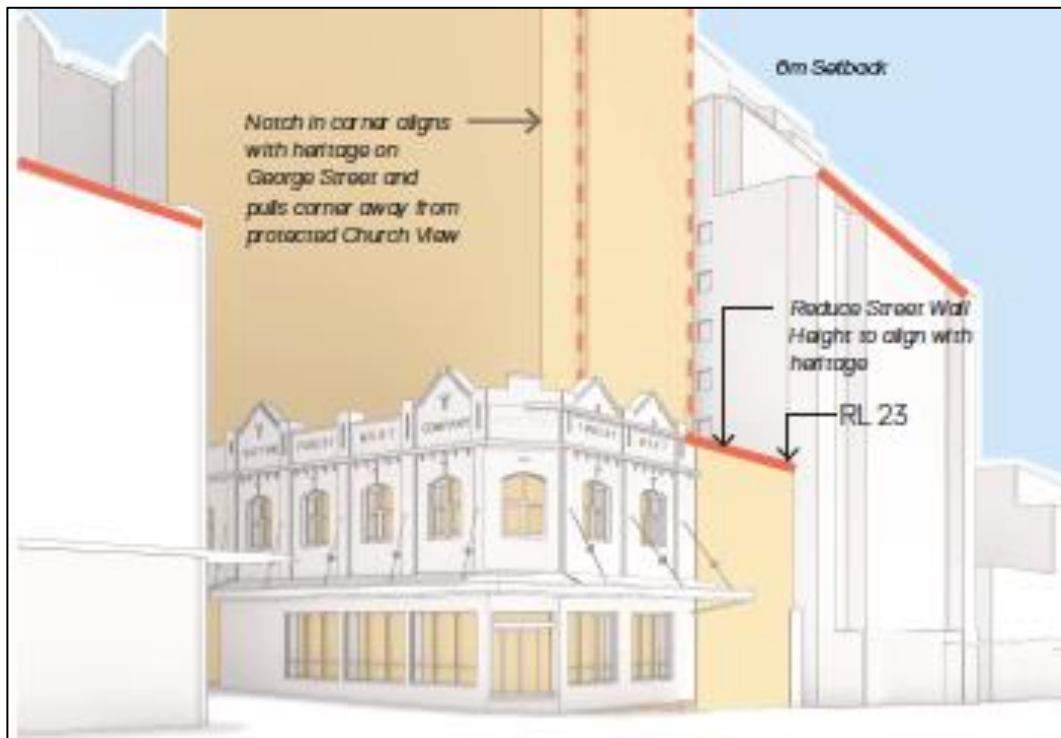

Figure 30 Proposed Setback and Street Wall Height
 Source: Grimshaw

9.1.2 Tower Element

The Draft CSPS situates the site within a Tower Cluster Area which permits towers to reach heights up to the airspace restrictions. Likewise, recently introduced controls for the adjacent Western Gateway sub-precinct permit towers in excess of RL 200. In consequence, the locality immediately surrounding the site is earmarked to undergo significant transformation and will accommodate towers of unprecedented heights (refer to **Figure 31**).

The proposed envelope provides for an intermediate scheme scale that is comparatively smaller in size relative to surrounding planned and future development permitted by the Draft CSPS controls.

The scale of the tower is appropriately proportionate for the site's size and facilitates the achievement of the relevant objectives prescribed under Sections 5.1.1 and 5.1.1.4 of the Draft DCP which include:

- *Ensure that tall buildings are slender and do not appear as walls or as overly massive from any direction.*
- *Heritage items create space between tall buildings that allow more sunlight, daylight and air circulation to the street.*
- *A tall building that is set back from its site boundaries that sits on a building podium creates space around it that provides light and air into the street.*

The scale of the Preferred Scheme in the context of the surrounding existing and future built form is illustrated in the **Figure 31**.

The site occupies a corner position and the tower element is setback from the southern street frontage and massed towards the side and rear boundaries. As the tower is substantially setback, it will have minimum visibility when viewed from the ground plane and the heritage façade will form the focal point of surrounding vistas (refer to **Section 9.3**). Consistent with the objectives, the positioning of the tower and its narrow floorplate provides for a tall and slender appearance (refer to **Figure 32**).

The tower element as envisaged by the Indicative Concept Scheme provides a compliant eastern side setback. The compliant setback combined with the site's corner location will facilitate light and air to the street, and will prevent the emergence of a wall of towers along both frontages should the surrounding sites be redeveloped.

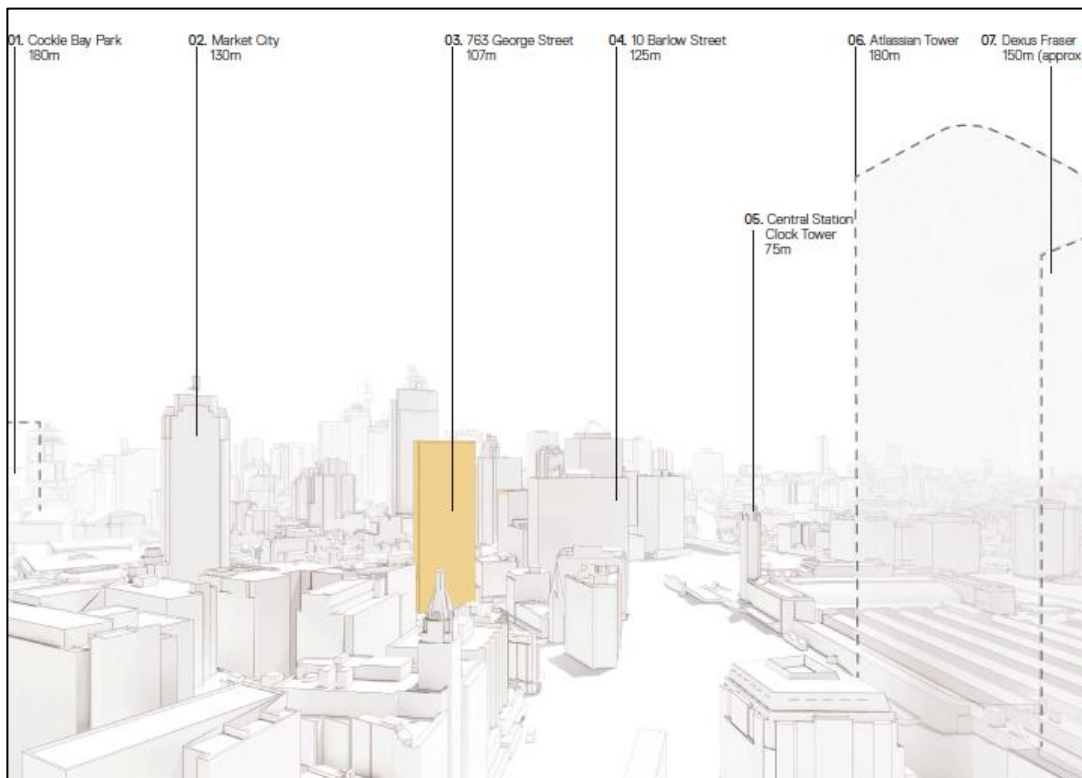

Figure 31 Proposal and Existing and Planning Towers Viewed Looking North
Source: Grimshaw



Figure 32 Proposal and Surrounding Further Developments Viewed Looking West
Source: Grimshaw

9.1.3 Tower Separation and Setbacks

The proposed setbacks have been prepared to comply with the requirements of the Draft DCP and to limit impacts to the adjoining properties and surrounding view corridors.

For a building of the proposed height (105.87m) located in the Haymarket / Chinatown Special Character Area, the Draft DCP prescribe the following setbacks which are to be applied consistently for the full height of the tower:

- Eastern Setback (George Street): 8m
- Northern Setback (Side/Rear): 4m
- Western Setback (Side/Rear): 4m
- Southern Setback (Valentine Street): Unspecified by the special character area mapping but is taken to be 10m as the site relates to a heritage item.

The Preferred Envelope provides tower setbacks generally in accordance with the Draft DCP (refer to **Figure 33**). Where non-compliances are proposed, they do not give rise to additional wind impacts or reduced daylight to the surrounding public domain. This is demonstrated by the Preferred Envelope's compliance with the equivalence tests prescribed by Procedure B of Schedule 11 (refer to **Section 9.4**).

In addition to complying with the equivalence tests, the sections below confirm that the proposed non-compliant setbacks provide acceptable amenity impacts.

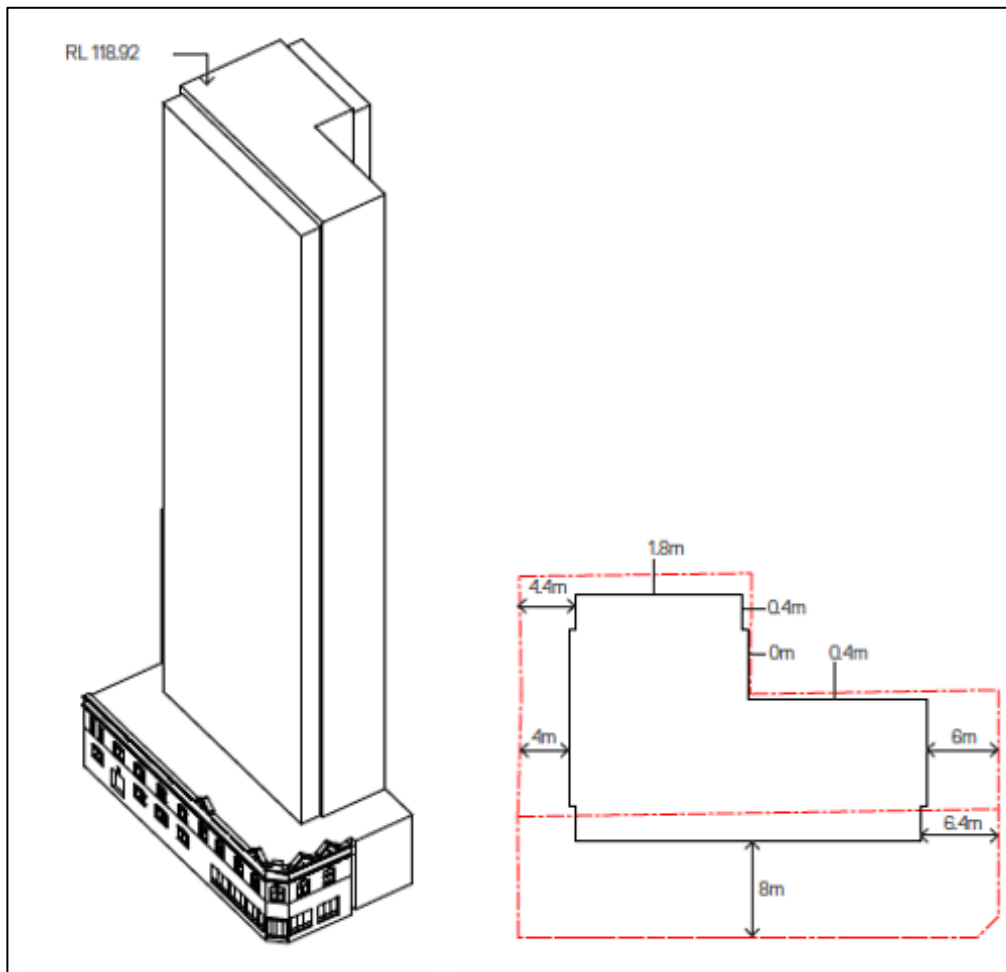

Figure 33 Proposed Massing and Tower Setbacks
 Source: Grimshaw

9.1.3.1 Northern Setback

Due consideration has been given to the design of the northern tower setback to prevent amenity impacts to the residential flat building to the north known as 'Capitol Terrace'.

The preferred envelope proposes a minimum 0.4 – 1.8m setback to the northern boundary, representing a non-compliance with the 4m minimum setback requirement prescribed by the Draft DCP (refer to **Figure 33**). Notwithstanding, it should be noted that this setback is increased by the driveway along the northern boundary.

Characterisation of the Interface

At the northern interface the southern elevation of the adjoining property incorporates a limited number of windows. These windows are illustrated below and primarily relate to secondary habitable spaces, including bedrooms and bathrooms (refer to **Figures 34 – 35**). A limited number of living spaces are affected; however, many of these spaces benefit from a dual aspect and are therefore provided with additional windows that orientate towards the west away from the subject site.

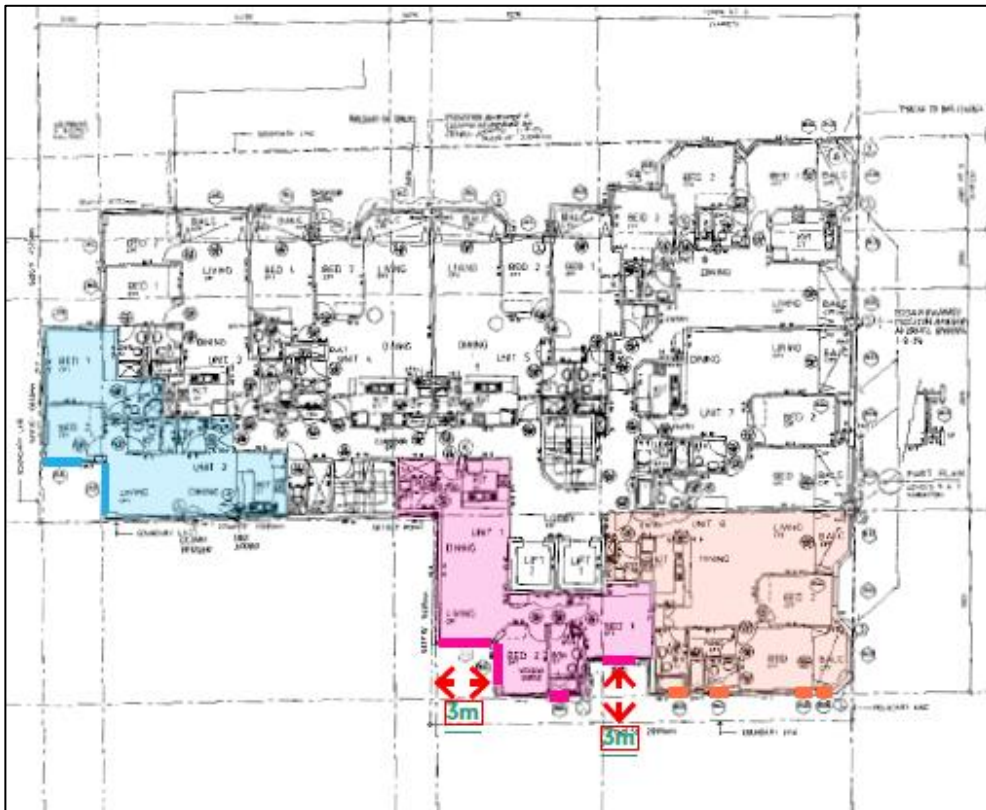

Figure 34 Typical Floor Plan of the 'Capitol Terrace' and Location of Windows
 Source: Grimshaw

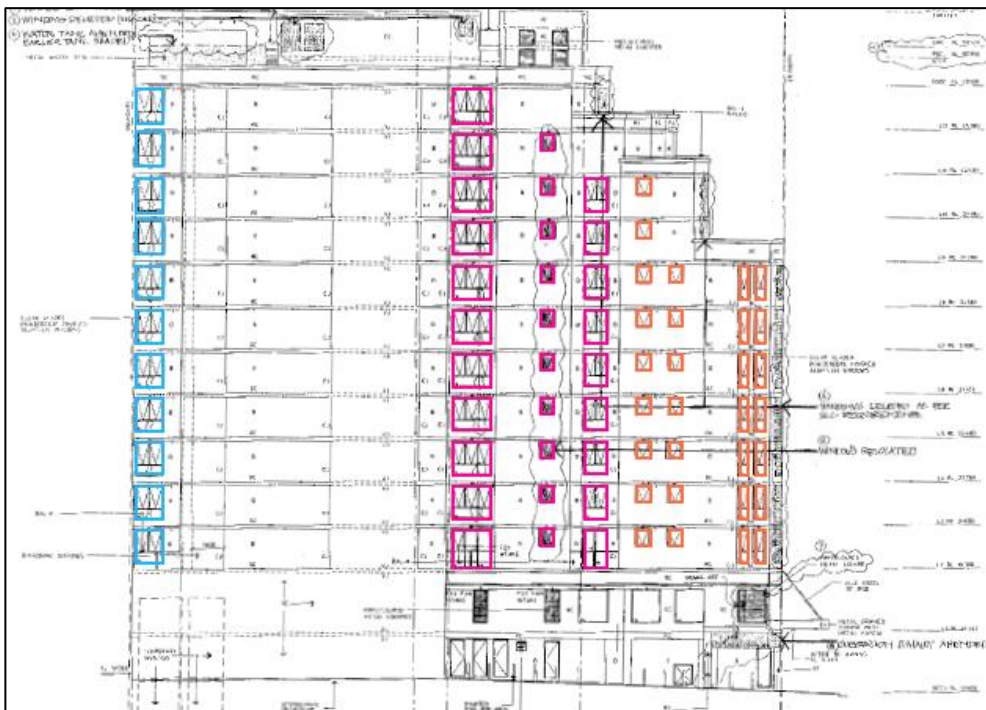

Figure 35 Location of Northern Building's Southern Facing Windows
 Source: Grimshaw

Visual Privacy Impacts

As demonstrated by the indicative Preferred Scheme, there is the potential to locate the lift core along the northern elevation where the envelope directly interfaces with the adjoining properties windows. The provision of a lift core in the proposed location precludes the opportunity for windows and balconies. In consequence, the reduced setback will not permit onlooking and give rise to visual privacy impacts.

As the northern property relates to a residential flat building, consideration needs to be given to *State Environmental Planning Policy No 65 – Design Quality of Residential Apartment Development* (SEPP 65) and the associated Apartment Design Guide (ADG). Section 3F of the ADG specifies that building separation is not required where an elevation is devoid of windows and balconies. Accordingly, the proposed setback and façade treatment is considered to be acceptable from a compliance perspective.

Private View Impacts

The proposed northern setback will not produce additional private view impacts beyond that of a complying scheme and the approved scheme. The extent of the view loss impacts associated with the proposed and complaint setbacks will be commensurate given that the affected view corridors under both scenarios will experience change and consist entirely of a tower element.

It is noted that the existing approval for the site (D/2017/353) permits a tower envelope with a nil setback to the northern property boundary. Relative to this approved envelope, the proposal represents an improvement as it provides greater building separation. In turn, it will not give rise to greater view loss impacts beyond that of the approved scheme.

Solar Impacts to Northern Property

Grimshaw have prepared a solar analysis to determine if the preferred envelope will provide increased solar impacts to the northern property relative to the existing building and the envelope approved under D/2017/353 (refer to **Appendix 2**).

The analysis confirms that the preferred scheme will result in equivalent solar impacts. As such, the adjacent northern property will continue to receive the same level of solar access irrespective of whether the site is developed in accordance with the approval or the preferred envelope.

9.1.3.2 Southern Setback

The Preferred Envelope proposes an 8m southern tower setback to Valentine Street which resultantly provides a 2m cantilevering element over the heritage item. The heritage fabric affected by the cantilevered element is non-significant, with only the facades fronting Valentine and George Street being of heritage value (refer to **Section 9.8**).

This tower setback is the outcome of extensive iterative design testing and is considered to best facilitate the achievement of the objectives/principles applicable to heritage items prescribed under Section 5.1.1.1 *Street Frontage Height and Street Setbacks* and the 2.1.3 *Haymarket/Chinatown Character Area Statement*.

The relevant objectives and principles include:

- *Heritage items create space between tall buildings that allow more sunlight, daylight and air circulation to the street.*
- *New development is to maintain and enhance vistas along Valentine Street and George Street to Christ Church Saint Laurence at 814A George Street and maintain vistas towards the clock tower of Central Station.*

The heritage item occupies a corner position and therefore generous circulation and space is provided around the building at street level. The proposed setback will not impact the provision of sunlight/daylight at the street level as evidenced by the Preferred Envelope's compliance with the equivalence tests.

The setback will preserve views and vistas along Valentine Street towards Christ Church Saint Laurence at 814A George Street. A view analysis of the Preferred Envelope from Valentine Street demonstrates the appropriateness of the proposed setback (refer to **Appendix 2**).

9.1.3.3 Eastern Setback

The proposal is required to provide an 8m tower setback to the George Street in accordance with the Draft DCP's Special Character Area mapping. The proposal provides a setback ranging from 6m - 6.4m. The setback is considered appropriate given the site occupies a corner location. Accordingly, there is no requirement to provide building separation.

As noted previously, the tower element is massed along the northern boundary. In consequence, the tower's massing where it interfaces with George Street presents as being a narrow tower form that is separated from the tower element. As a result, the heritage item stands in isolation of the proposed tower and forms the focal point of surrounding view corridors.

The proposed eastern setback does not cause the tower element to extend beyond the alignment of the Capitol Terrace apartments to the immediate north. Accordingly, the non-compliance will not obscure view corridors down George Street.

The eastern setback needs to be understood in the context of the proposed street wall height shown in **Figure 30**. As shown, the setback in conjunction with the proposed street wall height reduces the perceived massing of the Preferred Scheme at the prominent corner location, provides ample curtilage around the heritage item and enhances daylight to the ground plane.

9.1.3.4 Cantilevering Element

The tower element of the Preferred Scheme cantilevers over the heritage item. The proposed 2m encroachment over the heritage item is considered to be minor in that it extends over the heritage item's building footprint by no more than 16%.

In addition, its width is less than that permitted by the approval (DA/2017/353) which permits a 2.7m cantilevered element (including articulation) with a corresponding reduced southern setback of 7.3m.

As confirmed by the findings of the Heritage Impact Statement addressed in **Section 9.8**, the building fabric proposed to be cantilevered over is not of heritage significance, with the only significant fabric being the facades fronting Valentine and George streets.

The existing towers in the surrounds already compromise the setting of the item, with its facades only capable of being interpreted from the immediate streetscape as opposed to the distant surrounds. Being located in a Tower Cluster Area, it can be reasonably concluded that the item's setting will be further altered by future buildings developed under the Draft CSPS, including the potential tower to the immediate west at 187 Thomas Street that is currently the subject of a Planning Proposal. In turn, the heritage item and the tower associated with the Preferred Scheme will not be interpreted together in the round.

The cantilevered element is positioned a sufficient distance above the heritage item and provides an appropriate curtilage. It will not produce additional environmental impacts in that it:

- Will not provide additional material impacts to the fabric, including overshadowing, beyond that of a complying scheme;
- Will not restrict public views and vistas towards the heritage item;
- Is of minimal width and positioned a sufficient height above the heritage item to allow for its ongoing appreciation when viewed from the surrounding streetscape; and
- Is of minimal width and maintains sufficient airspace above to prevent any impact to the item's setting or create the perceived impression that the tower encloses and overwhelms the item.

The cantilevered element is in keeping with the approval for the site and integral to achieving a viable floorplate. Due to the massing of the tower in the northern portion of the site, the heritage item will continue to register as a standalone building. The generous airspace above the item will provide visual relief and will enhance the visual prominence of the item.

9.2 Overshadowing

Grimshaw have prepared an Overshadowing Analysis which is included at *Appendix K* of their Architectural Design Report (refer to **Appendix 2**). The analysis addresses the proposal's compliance with the applicable Sun Access Plane (SAP) provisions that aim to protect sunlight to nearby public places.

Of relevance to the proposal is the SAP for Belmore Park prescribed by the Draft DCP which is intended to protect sunlight to this important public space between 10am to 2pm at all times of the year. The DCP Envelope and Preferred Scheme will not intersect with the Belmore Park SAPs and therefore will not overshadow this public place.

Whilst not identified in the Draft DCP, consideration has also been given to the SAP for Railway Square which is addressed in *Appendix M* of the Draft CSPS. The SAP is intended to protect sunlight to Railway Square between 9am to 2pm mid summer and 11am to 12pm mid winter.

The analysis prepared by Grimshaw demonstrates that the DCP Envelope and Preferred Scheme will not intersect the Railway Square SAP (refer to **Figure 36**). Accordingly, the proposal will provide no additional overshadowing to Railway Square between 11am to 12pm during the Winter Solstice, which represents the worst case scenario.

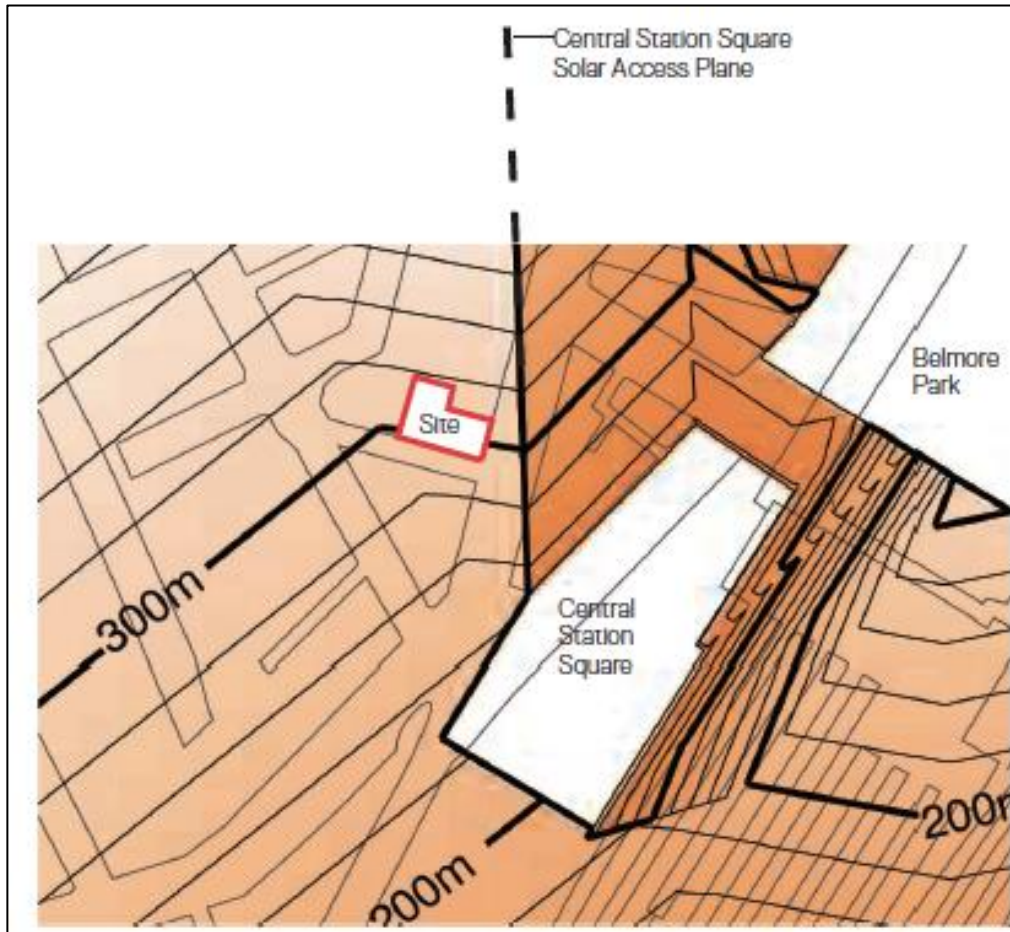

Figure 36 Railway Square Solar Access Plan in Relation to the Site
Source: Grimshaw / Draft CSPA

9.3 Visual Impact

Grimshaw have prepared photomontages of the Preferred Scheme in the streetscape to facilitate a Visual Impact Analysis of the proposal (refer to **Appendix 2**). The analysis illustrates the Preferred Envelope when viewed from significant public vantage points, including those in the immediate streetscape and distant surrounds. The analysis has also accounted for future tower developments that will be visible in the background and will redefine the Preferred Scheme's visual setting.

Immediate Surrounds

The site is located within the Haymarket/Chinatown Special Character Area. The Special Character Area Statement identifies that the locality is typified by its fine-grained subdivision pattern, low street walls and the absence of tower forms. In light of this, the Principles for the Special Character Area require the following:

- *Retain and enhance the urban character and scale of the Haymarket Locality by having street frontage heights consistent with the prevailing form of heritage items and providing setbacks above those street frontage heights; and*
- *Maintain and enhance vistas along Valentine Street and George Street to Christ Church Saint Laurence.*

As shown in the figures below, the contemporary additions proposed by the Preferred Scheme have minimal visibility when viewed from the immediate streetscape.

The tower element is recessed behind the street wall height by a generous upper setback. Consequently, it has minimal visibility when viewed looking east down Valentine Street frontage, allowing the fine-grained podiums dominant the vistas available at street level (refer to **Figure 37**).

Where the tower element is visible, it presents as being a continuation of the upper street wall height and does not encroach on views of Christ Church Saint Laurence. As shown in **Figure 38**, the tower is well separated from the Christ Church Saint Laurence, allowing for large expanses of sky to surround the historically significant Church. In turn, the proposal will have no impact on the Church's visual setting.

The retention of the heritage item combined with the setting back of the tower element preserves the existing urban character and scale of the Haymarket locality, and therefore satisfies the requirements of the Draft DCP. This is evidenced by the figure below, which demonstrates that when viewed looking east down Valentine Street, the site's heritage building presents as being the most visually prominent element.

When viewed from the George Street frontage, the proposed podium element aligns with the street wall height of the heritage building (refer to **Figure 39**). By virtue of the tower's narrow floorplate and its massing along the northern boundary away from the heritage building, the tower element reflects a slender form and does not dominant the view nor does it provide a sense of enclosure that would detract from the heritage building.



Figure 37 View Down Valentine Street Towards Christ Church St Laurence
Source: Grimshaw



Figure 38 View from Thomas and Quay Streets Looking East
Source: Grimshaw



Figure 39 View from the George Street Frontage Looking South West
 Source: Grimshaw

Distant Surrounds

The Draft DCP nominates a range of significant public views that require protection. As shown in **Figure 40**, the proposal is situated a considerable distance from Central Station Clock Tower and will have no impact on the associated view corridor that aims to ensure the landmark will remain visible against the sky.



Figure 40 Public Views Protection Map / Central Station Clock Tower View Corridor
 Source: Draft CSPA

The Draft DCP requires that consideration be given to additional significant views not mapped in **Figure 40**. To address this requirement, Grimshaw have prepared an analysis of the Preferred Scheme's visual impacts when viewed from the distant surrounds.

As shown in **Figure 41**, the proposal will sit comfortably within the skyline when viewed in the context of surrounding future developments of a greater height. The Preferred Scheme provides a slender form that will assist in preserving sky views, maintaining sightlines between towers and providing an intermediate scale that complements the surrounding future built forms. Being within a Tower Cluster Area, it can reasonably be expected that additional future tower developments of a commensurate or larger scale will occupy the skyline. In this context, the proposal will not dominate the skyline.



Figure 41 View of Preferred Envelope from Railway Square Looking West
Source: Grimshaw

9.4 Equivalence Testing

The proposal varies the setback provisions prescribed by the Draft DCP. Setback variations are permitted for the site in accordance with the Draft DCP Special Character Area mapping set out in the Draft DCP.

To demonstrate the acceptability of the proposed setback variations, the DCP Envelope / Preferred Scheme and associated envelope options developed for the design competition phase have been subject to the equivalence testing procedure established by Procedure B, Schedule 11 of the Draft DCP.

The equivalence testing procedure requires that proposals provide equal or improved pedestrian wind comfort and daylight levels at the ground plane notwithstanding the proposed non-compliances with the setback provisions. To

demonstrate this, the daylight and wind impacts are required to be compared against a Base Case Envelope that complies with the massing controls established under Procedure B.

The results of the equivalence testing demonstrate that the setback variations will result in equivalent pedestrian wind impacts and improved daylight at the ground plane. A detailed discussion is provided below and *Appendices D – E* of the Architectural Design Report at **Appendix 2**.

9.4.1 Daylight Analysis

Sky View Factor (SVF) is a proxy used for measuring daylight levels and the extent of sky observable at the ground plane. The SVF has been calculated using a 1m grid and a test radius from the site of 250m, which encompasses the future Railway Square. The SVF results for the Base Case Envelope have been compared against those associated with the proposed DCP Envelope and alternative envelope options (refer to **Appendix 2**). As the Preferred Scheme fits within the DCP envelope, the results are applicable to the Preferred Scheme.

The results for the DCP Envelope and alternative envelope options demonstrate an improvement from the Base Case Envelope. With respect to the DCP Envelope / Preferred Scheme, the findings confirm that when averaged there is an overall difference of 0.000008% in the SVF within proximity of the site.

In light of the above, the Preferred Scheme and envelope options will maintain an acceptable level of daylight access to the public domain.

9.4.2 Pedestrian Wind Comfort and Safety

Windtech have prepared a Pedestrian Wind Environment Study which is included at **Appendix 10**. The study has been prepared to address if the proposal is capable of achieving equivalent or improved wind safety and comfort. The study assesses the wind conditions associated with the following:

- The DCP Envelope / Preferred Scheme;
- The Base Case Envelope;
- Alternative envelope options developed for the design competition phase; and
- The site's existing built form.

The results confirm that all envelope variants listed above comply with the requirements of the equivalence testing prescribed by Schedule 11 of the Draft DCP subject to the adoption of the two recommendations included within the study.

The first recommendation relates to the provision of an impermeable awning along the northern and eastern aspects of the building, with a small return along the south aspect.

The second recommendation requires that the level of the podium that meets the base of the tower in the site's north-western corner be configured to minimise north-east winds and direct winds around the affected corner. It is envisaged that the configuration could potentially consist of the inclusion of an increased western setback or a podium cut out in the suggested location. However, the exact

configuration would need to be determined with regard to further wind testing at the detailed Development Application phase. Notwithstanding, any necessary reconfiguration can readily be accommodated within the proposed DCP Envelope.

9.5 Design Excellence

The future development facilitated by this Planning Proposal will be subject to an architectural design competition in accordance with the requirements of clause 6.21 of the SLEP 2012.

The Planning Proposal is accompanied by a Design Excellence Strategy included at **Appendix 11**. The Design Excellence Strategy has been prepared in accordance with the *City of Sydney Competitive Design Policy*, the *Draft Amendment to Competitive Design Policy* and the *Tower Cluster Areas and Design Excellence Procedure Amendment*.

It is noted that Tower Cluster Area sites subject to subclause 6.21(7A) of the SLEP 2012 (as proposed under the CSPS) are required to comply with the requirements of the *Tower Cluster Areas and Design Excellence Procedure Amendment* and the *City of Sydney Competitive Design Policy* as amended by the *Draft Amendment to Competitive Design Policy*, which necessitate the undertaking of an invited architectural design competition with a minimum of six (6) consortiums.

The proposal has not been prepared pursuant to subclause 6.21(7A) of the SLEP 2012 due to the site's area being less than 2,000m². Notwithstanding, the proposal includes a commitment to undertaking an invited architectural design competition to satisfy the design excellence requirements that apply to applications prepared pursuant to subclause 6.21(7A).

The invited architectural design competition will consist of a minimum of six (6) consortiums and a competition jury comprising a minimum of six (6) members. The composition of the consortiums and jury will be in accordance with the requirements set out in **Appendix 11**.

The accompanying draft Site Specific DCP at **Appendix 4** nominates design excellence provisions for the future design competition. It identifies that the LEP amendments sought by this Planning Proposal assume that the 10% design excellence bonus will be accommodated in the DCP Envelope. This envelope therefore reflects the maximum density attainable for the site.

9.6 Solar Access

LCI Consultants have prepared a Daylight Analysis to assess the level of daylight penetration achieved across the hotel suites (refer to **Appendix 12**). A minimum daylight factor of 2% is identified to be the target. To facilitate the assessment, the daylight levels and lux levels were identified within each hotel suite.

The modelling confirms that dual aspect suites are capable of receiving adequate solar access. Single aspect apartments receive less solar; however, only the rear of the suites receive low levels of daylight. These areas will likely accommodate bathrooms and consequently do not require solar.

The report concludes that subject to the adoption of the glazing recommendations outlined in the report which facilitate greater light penetration, each hotel suite within the Preferred Scheme is capable of meeting the minimum daylight factor target of 2%.

9.7 Noise Impacts

White Noise Acoustics have prepared a Noise Impact Assessment for the Preferred Scheme which is included at **Appendix 13**. The assessment demonstrates that a future hotel development for the site will not be affected by unacceptable noise intrusion nor will it provide unacceptable noise emissions to surrounding receivers.

Internal Noise Assessment

The Noise Impact Assessment has evaluated the noise impacts likely to affect the proposal and whether it is capable of incorporating suitable acoustic treatments to prevent unacceptable noise intrusion.

The calculation of the internal noise levels accounts for environmental noise levels in the surrounds, including traffic and aircraft background noise, along with the Preferred Scheme's design. The report confirms that the proposal is capable of meeting the internal noise levels nominated by the SDCP 2012 (Section 4.2.11.1) subject to incorporating the recommended glazing constructions detailed in the report.

External Noise Assessment

The Noise Impact Assessment evaluates the external noise emissions that may emanate from the future building and affect nearby receivers, including surrounding commercial uses and the residential building to the immediate north.

The assessment is based on a noise level survey conducted on the site. This survey has been conducted to evaluate the proposal against the intrusive and amenity noise level criteria prescribed by the NSW Environmental Protection Authority's (EPA) *Noise Policy for Industry and Council's General Noise Emissions Criteria*. The assessment identifies that mechanical plant associated with the future building will be the primary source of noise emissions.

The Noise Impact Assessment concludes that with the adoption of the recommendations, including appropriate glazing and acoustically treated mechanically services, the proposal is capable of achieving the relevant noise criteria. As such, the proposal will not provide unacceptable noise impacts to future occupants or surrounding properties.

9.8 Heritage

Weir Phillips have prepared a Heritage Impact Statement that is included at **Appendix 14**. The report provides an assessment of potential impacts to the locally listed heritage listed building contained within the site and the heritage items in the surrounds.

Weir Phillips have determined that the interiors of the Sutton Forest Meat Building are not of heritage significance due to previous fire damaged and alterations to facilitate the fitout and use of the site.

The Heritage Impact Assessment identifies that the proposal will have no impact on the heritage item. A summary of Weir Phillip's findings are as follows:

- The tower element is adequately separated and distanced from the item which ensures it retains its corner prominence;
- The architectural expression of the Preferred Scheme is sympathetic to the heritage item in that the podium relates to the composition of the building and maintains the lower scale streetscape rhythm;
- The existing height and surrounding built form provide a high rise setting to which the additional height will not have a perceptible impact when viewed from street level;
- The development facilitated by the proposal will retain and restore the original features of the building and will enhance its contribution to the streetscape;
- The proposed works will have no material or structural impact on the heritage building; and
- The proposal will have no impact on the significance of the building's interiors which have already been substantially altered and damaged.

The Heritage Impact Statement notes that a future development will include a detailed scope of works for the conservation of the retained fabric to ensure that it is appropriately treated and to prevent impacts to its fabric. It is anticipated that a façade retention strategy addressing stabilisation and demolition works will be provided as part of the detailed Development Application.

Surrounding Heritage Items

The Heritage Impact Statement identifies that the development facilitated by the Planning Proposal will have no adverse impact on the heritage items in the surrounds. Specifically, the assessment notes that the proposal will have no impact on significant view corridors to heritage items including Central Station Clock Tower, the Sydney Terminal and Central Railway Station Group and Christ Church Staint Laurence. This conclusion is drawn on the basis that the proposed tower is sited and massed in the northern portion of the site above the none heritage listed building. In consequence, the tower addition largely independent of the heritage item, allowing it to sit in isolation and to be interpreted in isolation of the proposed tower.

Archeology

Austral Archeology have prepared a Historical Archaeological Assessment Report which is included at **Appendix 15**. The findings of the assessment confirm that the site has the potential to contain archeological remains consisting of structures, yard surfaces and outbuildings associated with mid to late 19th century residential and commercial structures of historical and social significance.

The report recommends that a permit required under Section 139 of the *NSW Heritage Act 1977* be obtained prior to any construction works. It also recommends that a State of Heritage Impact be prepared to address any mitigation measures to prevent potential impacts to archeological remains.

9.9 Transport, Traffic and Parking

A Traffic Impact Assessment has been prepared by Traffix and is included at **Appendix 16**. The report provides a statutory parking assessment; an assessment of the traffic generation associated with the preferred scheme; and a review of the access arrangements and internal basement design.

9.9.1 Statutory Parking Assessment

Traffix have prepared a statutory parking assessment. The findings are discussed in the sections below.

Car Parking

The SLEP 2012 prescribes the maximum parking provisions for the site. Based on a total of 280 hotel rooms and 171m² of retail GFA, the proposal is permitted to provide a maximum quantity of 63 vehicle spaces. The proposal provides a total of seven (7) vehicular spaces for valet parking that are proposed to be accommodated within the basement. The proposal therefore does not exceed the maximum parking rate that applies to the site and complies with the SLEP 2012.

The Preferred Scheme provides a reduced quantity of parking to capitalise on its proximity to public transport and to limit traffic generation in the surrounding road network.

Bicycle Parking and EOT Facilities

The SDCP 2012 nominates minimum bicycle parking and end-of-trip (EOT) rates. Traffix confirm that the internal basement layout is capable of accommodating the minimum bicycle and EOT requirements at the detailed DA phase.

Motorcycle Parking

The SDCP 2012 requires the provision of motorcycle parking at a rate of 1 space per 12 car parking spaces. Based on the proposed seven (7) car parking spaces, the proposal is required to provide one (1) motorcycle space. Traffix confirm that the required motorcycle parking is capable of inclusion within the basement level at the detailed DA phase.

Servicing

Based on the proposed mix of uses, the SDCP 2012 requires the provision of seven (7) loading bays. The proposal provides one (1) loading bay which represents a non-compliance with the control.

Traffix have provided a detailed justification for the variation, noting that the servicing rates prescribed by Council assume that the land uses will be provided independently. The DCP therefore does not account for the possibility of a managed approach, with shared use of the loading bay at various times of the day. It is anticipated that the loading bay will be used up to four (4) times any given day and service vehicles entering and leaving the site can be adequately be managed using a Loading Dock Management Plan (LDMP).

9.9.2 Traffic Generation

Traffix have assessed the traffic generation associated with the Preferred Scheme. It is estimated that the Preferred Scheme will generate:

- 28 vehicle trips per hour during the morning peak period; and
- 32 vehicles per house during the evening peak period.

The report confirms that the anticipated traffic generation can readily be accommodated within the surrounding road network without the need for road upgrades.

9.9.3 Access Arrangements

Traffix have assessed the access arrangements of the Preferred Scheme. Their assessment confirms that the proposed driveway entrance from Valentine Street, car lift system and internal layout comply with the relevant Australian Standards. A Swept Path Analysis accompanies the report and demonstrates that vehicles can satisfactorily maneuver in and out of the site.

9.10 Geotechnical

A Preliminary Geotechnical Report has been prepared by El Australia and is included at **Appendix 17**. The report identifies that the site's subsurface conditions comprise the following:

- Fill comprising brick, concrete, shale and sandstone;
- Residual soil; and
- Weathered sandstone.

El Australia specify that excavation to a depth of 9.5m below existing ground level is required to facilitate the construction of the basement. The report recommends that whilst groundwater seepage was not encountered during the drilling of boreholes used to assess the soil profiles, further monitoring should be carried out during bulk excavation phase to monitor possible seepage.

In addition to the above, the Preliminary Geotechnical Report details a range of other recommendations relating to footings, anchors, retention walls and underfloor drainage which are to be adopted during the construction phase. In particular, it is noted that as the proposed basement extends up to the site's boundary an engineered shoring wall is required to facilitate the excavation process.

The report concludes that with the adoption of the recommendations, the site is capable of being redeveloped without impacting adjoining properties.

9.11 Contamination

A Remediation Action Plan (the RAP) has been prepared by El Australia and is included at **Appendix 8**. The RAP identifies the measures required to remediate the site and make it suitable for the proposed development.

El Australia note that the primary sources of contamination relate to remaining in-situ underground petroleum storage systems and groundwater contaminated by heavy metals such as nickel and zinc. The RAP consists of the following:

- Hazardous materials assessment;
- Site demolition to allow further assessment, particularly in the site southern portion;
- Removal of sources of contamination by decommissioning and appropriate off-site disposal; and
- Classification and bulk excavation of soils, appropriate off-site disposal and remediation of impacted soils.

The RAP notes that the site's groundwater may require further assessment and remediation at a later stage. Overall, the report confirms that with the adoption of the proposed remediation strategy, the site can be made suitable for the proposal.

9.12 Stormwater

Stormwater Concept Plans have been prepared by Australian Consulting Engineers and are included at **Appendix 18**.

The plans confirm that appropriate stormwater measures are capable of adoption at the detailed design phase. The stormwater measures consist of a pump out system, with a pump-out storage tank proposed below the lower level basement carpark. Preliminary MUSIC modelling confirms that the proposed stormwater measures can achieve adequate water quality.

9.13 Public Art

Site Image Public Art Consultants have prepared a Preliminary Public Art Plan (the Plan) which is included at **Appendix 19**. The Plan has been prepared to identify opportunities for public art associated with the Preferred Scheme and to confirm that the proposal is capable of complying with Council's *Interim Guidelines – Public Art in Private Developments*. The Plan identifies three (3) opportunities for public art, including:

- 1) Wall art on the lift core adjacent to the laneway;
- 2) Floor inlay art along George Street Laneway; and
- 3) A canopy element over George Street Laneway.

The corresponding location of each option identified above is shown in **Figure 42**.

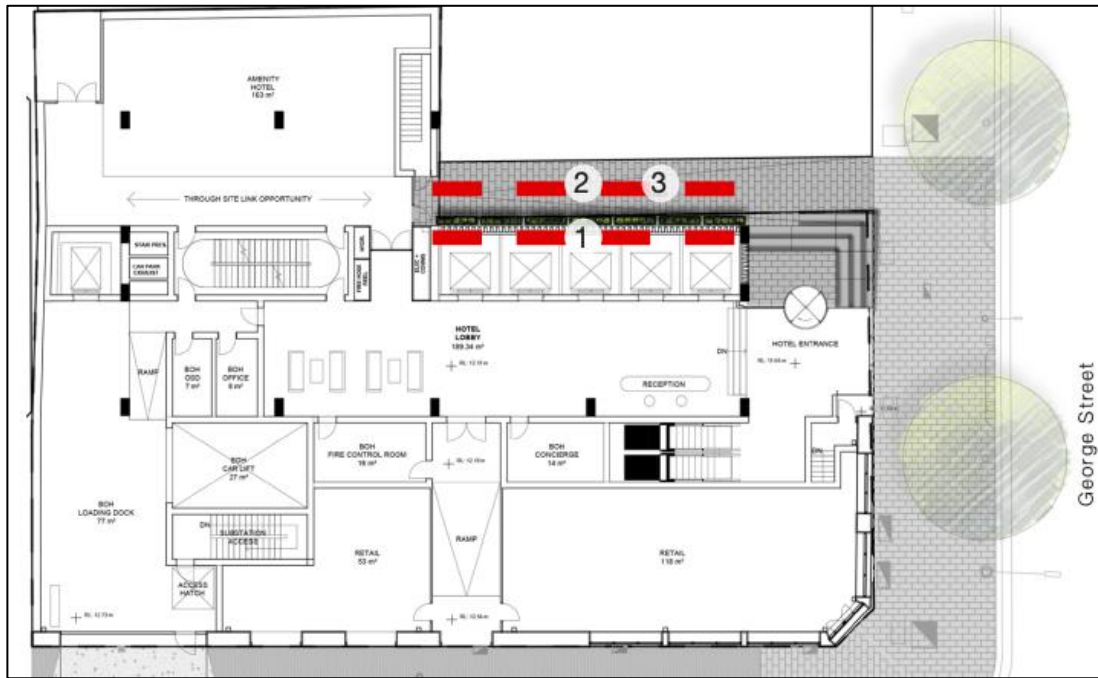

Figure 42 Potential Locations for Public Art Within Site
 Source: Site Image Public Art Consultants

As set out in the Plan, it is envisaged that any future public art for the site will be prepared and curated by a public artist selected in accordance with Councils guidelines.

9.14 Sustainability

It is intended that the future development for the site will adopt best practice sustainability measures. The ecologically sustainable benchmark commitments include:

- A 5 Star Green Design and As-Built v1.3 rating; and
- A 5 Star NABERS Energy Hotel Whole Building rating.

The ecologically sustainable strategies include:

- Passive heating and cooling techniques;
- Water sensitive urban design measures;
- High efficient fixtures and fittings;
- A photovoltaic system;
- Provision of energy efficient lighting and mechanical services to meet NABERS requirements; and
- Low embodied energy efficient materials.

Further details pertaining to the ESD Strategy for the Preferred Scheme are included in the ESD Report prepared by LCI Consultants at **Appendix 6**.

9.15 Voluntary Planning Agreement

In accordance with Section 7.4 of the EP&A Act, the Proponent is committed to entering into a Voluntary Planning Agreement (VPA) with Council. The VPA will make provision for public benefits in accordance with Council's relevant contributions plan and *Planning Agreements Policy* (2016). A Public Benefit Offer is provided under Separate Cover.

9.16 Social and Economic Benefits

The proposal will provide the following social and economic benefits:

- Provision of 12,318m² employment generating floor space;
- Employment generation including 127 operational jobs;
- Support to the growth of Sydney's visitor economy by providing a high quality hotel within a growing tech precinct that will experience an influx of corporate travelers and leisure visitors;
- Indirect economic benefits including an estimated \$8.5m of investment in the local economy by 2025 due to expenditure from hotel visitors;
- Retail activation at the ground plane that will complement Council's vision for the Central Square and the pedestrianisation of the area;
- Public domain improvements that will enhance the amenity of the streetscape and improve legibility;
- Additional hotel floor space that will contribute to meeting the growing demand for mid-range hotel accommodation;
- Opportunities for the integration of public art;
- Retail activation that will contribute to the revitalisation of the area;
- Adaptive reuse of the heritage item to protect the unique character of the Haymarket / Chinatown Special Character Area;
- Opportunity for the inclusion of a through-site link; and
- A hotel that adopts best practice sustainability measures.

10 Mapping

The proposed amendments do not necessitate changes to the mapping accompanies the SLEP 2012.

11 Community Consultation

The Planning Proposal will be placed on public exhibition in accordance with the Gateway Determination, should the Department of Planning and Environment support the proposal.

A comprehensive engagement strategy will be prepared by Council which would include the following mechanisms:

- 4) Advertisement in a local newspaper which is circulated within the local government area;
- 5) Notification letters to relevant State Agencies and other authorities nominated by the DPIE;
- 6) Notification (via letter) to land holders of properties within and adjoining the Precinct;
- 7) Advertise and exhibit the Planning Proposal on Council's website and at the Customer Service Centre; and
- 8) Undertake any other consultation methods appropriate for the proposal.

12 Indicative Project Timeline

The project timeline has been provided to assist with monitoring the progress of the Planning Proposal through the plan making process and assist with resourcing to reduce potential delays.

Table 14 – Project Timeline	
Milestone	Date
Submission of the Planning Proposal	October 2020
Planning Proposal Reported to Council	December 2020
Referral to Minister for Gateway Determination	December 2020
Anticipated commencement date (date of Gateway determination)	January / February 2021
Commencement and completion dates for public exhibition period	February / March 2021
Timeframe for government agency consultation (pre and post exhibition as required by Gateway determination)	June – July 2021
Timeframe for consideration of submissions	July / August 2021
Timeframe for consideration of a proposal post exhibition	August / September 2021
Consideration of PP by Council (Council Meeting)	September / October 2021
Date of submission to the DPIE to finalise the LEP	November 2021
Anticipated date RPA will make the plan (if delegated) or Anticipated date RPA will forward to the department for notification	December 2021
Anticipated date for publishing of the plan	December / January 2021

13 Conclusion

This report has been prepared by Mecone to support a Planning Proposal to Council. It has been prepared in accordance with Section 3.33 of the EP&A Act and addresses the requirements set out in the DPIE's 'A Guide to Preparing Planning Proposals' (2016).

The Planning Proposal provides a justification for the proposed amendments to the SLEP 2012 with respect to the site at 757 – 763 George Street, Sydney. The proposed amendments include the introduction of a site specific clause to Division 5 of the SLEP 2012 to establish a maximum:

- Building height of RL 117.87 (105.87m from ground level);
- FSR of 12:1 above ground; and
- FSR of 2:0 below ground for specific ancillary uses.

The Planning Proposal will support a high quality commercial tower containing mid-range hotel accommodation that will achieve a number of positive outcome and satisfies the strategic and site specific merit tests.

It is considered that the Proposal will:

- Increase the capacity for the site to accommodate employment generating floor space conducive to facilitating job creation;
- Provide a development that responds to the site's context by delivering a tower with an intermediate scale relative to the super towers in the surrounds and will facilitate a gradual transition in scale;
- Prioritise a pedestrian focused environment by activating Valentine and George Street;
- Deliver mid-range accommodation that will address the demand for affordable tourist accommodation options in the context of there being an oversupply of high-range hotels;
- Demonstrates strategic merit as it aligns with the applicable regional and local strategic plans;
- Will adaptively reuse the heritage item contained within the site by conserving its significant fabric whilst delivering a contemporary tower addition;
- Demonstrates site specific merit in that it will not result in unacceptable environmental impacts as demonstrated by the assessment above; and
- Provides public domain improvements at the ground plane that will complement the upgrades envisaged for Haymarket under the Central Square Structuring Principles.

As demonstrated by the above assessment, the proposal satisfies the Site Specific Merit Test and Strategic Merit Test. It also responds to a change in circumstances, with this being the growth of the office market associated with the Haymarket / Ultimo Tower Cluster Area and the Sydney Innovation and Technology Precinct, and the associated demand for accommodation floorspace.



mecone

Level 12, 179 Elizabeth St
Sydney, NSW, 2000

info@mecone.com.au
mecone.com.au